

RaiIRTU



Installation and Operation

PREFACE

<p style="text-align: center;">RailRTU Installation and Operation January 2002</p>

This manual represents your meter as manufactured at the time of publication. It assumes standard software. Special versions of software may be fitted, in which case you will be provided with additional details.

Every effort has been made to ensure that the information in this manual is complete and accurate. We revised this manual but cannot be held responsible for errors or omissions.

The apparatus has been designed and tested in accordance with EN 61010-1, 'Safety Requirements for Electrical Equipment for Measurement, Control and Laboratory Use'. This operating guide contains information and warnings which must be followed by the user to ensure safe operation and to maintain the apparatus in a safe condition.

We reserve the right to make changes and improvements to the product without obligation to incorporate these changes and improvements into units previously shipped.

General Editor : Ian Sykes BSc (hons).

Copyright © 2002 : Northern Design (Electronics) Ltd,
228 Bolton Road, Bradford. West Yorkshire. UK.

Table Of Contents

1.	SAFETY	6
1.1	WARNING SYMBOLS.....	6
1.2	MAINTENANCE	6
2.	METER OPERATION.....	7
2.1	MEASUREMENTS.....	7
2.1.1	Balance Current Measurements.....	7
2.1.2	Rolling Demand (V, I and kW Demand)	8
2.1.3	Percentage THD.....	10
2.2	BAUD/ADDRESS DISPLAY.....	11
2.3	MODBUS DIAGNOSTIC LEADS	11
2.4	ISOLATED PULSE OUTPUTS	12
2.5	SETTING BAUD/ADDRESS.....	14
3.	INSTALLATION	15
3.1	RAIL MOUNTING.....	15
3.2	CT CONNECTIONS (I1-I3).....	15
3.3	VOLTAGE CONNECTIONS (VN, V1-V3).....	16
3.4	AUXILIARY MAINS SUPPLY (L & N).....	16
3.5	CONNECTION SCHEMATICS.....	17
4.	MODBUS COMMUNICATION	20
4.1	DESCRIPTION.....	20
4.1.1	Communication Address	20
4.1.2	Data Format.....	20
4.2	RS485.....	21
4.2.1	RS485 Connection	21
4.3	MODBUS PROTOCOL.....	24
4.3.1	An Introduction To Modbus	24
4.3.2	RTU. Transmission Mode.....	25
4.3.3	CRC ERROR CHECKING	27
4.4	RAILRTU DATA TABLES	30
4.4.1	Table 2 Accumulated Energy Readings	31
4.4.2	Table 11 Instantaneous Meter Values.....	33
4.4.3	Table 12 Additional Instantaneous Values	34
4.4.4	Table 13 Peak Values	34
4.4.5	Table 14 Meter Set-up.....	36
4.4.6	Table 16 Current and Voltage Demand.....	37
4.4.7	Table 17 Current and Voltage Distortion.....	38

4.5	RTU COMMANDS.....	39
4.5.1	<i>Function 04 (or 03) Read Multiple Registers.....</i>	39
4.5.2	<i>Function 06 Preset a Single Register.....</i>	41
4.5.3	<i>Function 08 Loop Back Diagnostic.....</i>	43
4.5.4	<i>Function 16 Preset Multiple Registers</i>	45
4.5.5	<i>Exception Responses.....</i>	47
5.	SPECIFICATION	49

1. Safety

1.1 Warning Symbols

This manual provides details of safe installation and operation of the meter. Safety may be impaired if the instructions are not followed. Labels on individual meters give details of equipment ratings for safe operation. Take time to examine all labels on the meter and to read this manual before commencing installation.



Caution

Refer to User Instructions

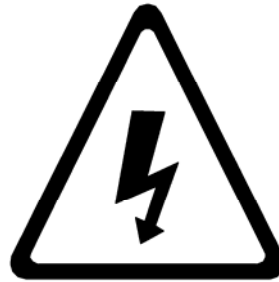

Danger

Risk of Electric Shock

Figure 1-1 Safety Symbols

WARNING

The meter contains no user serviceable parts. Installation and commissioning should be carried out by qualified personnel

1.2 Maintenance

The equipment should be maintained in good working order. Damage to the product should be repaired by the manufacturer. The meter may be cleaned by wiping lightly with a soft cloth. No solvents or cleaning agents should be used. All inputs and supplies must be isolated before cleaning any part of the equipment.

2. Meter Operation

2.1 Measurements

The RailRTU makes use of a high speed micro-processor and an Analogue to Digital converter to monitor input signals from three independent phases. Each phase voltage, current and power (kW) are measured directly and a number of other parameters derived from these in software. The measurement process is continuous with all six signals scanned simultaneously at high speed. Unlike many other sampling systems, which sample one phase after another, this ensures that all input cycles are detected. Distorted input waveforms, with harmonics to the 20th are therefore detected accurately.

Derived parameters are calculated once a second then scaled by user programmed constants for current and voltage transformers.

Instantaneous power parameters are integrated over long time periods providing a number of energy registers. System frequency is detected by digital processing of the phase 1 voltage signal.

2.1.1 Balance Current Measurements

The total current in a three phase system may be represented as :

$$\mathbf{I_{ba1}} = \mathbf{I_1} + \mathbf{I_2} + \mathbf{I_3} = \mathbf{I_{LEAK}} + \mathbf{I_n}$$

$\mathbf{I_{ba1}}$ is the balance phase current (Leakage + Neutral currents)

$\mathbf{I_{LEAK}}$ is any current leaving the system (e.g. Leakage to earth)

$\mathbf{I_n}$ is the current in the neutral (4 wire systems only)

NOTE In 3-Phase 3-Wire systems the RailRTU must be wired using 3 CTs as shown in Section 3.5 for balanced current measurements to be made.

Meter Operation

2.1.2 Rolling Demand (V, I and kW Demand)

Average values of volts, Amps and kW are calculated over a user programmable time period (10 - 2500 seconds for V and I, 1 - 60 minutes for kW). These calculated values represent the averages for the most recent time period ending at the present time. The demand period is continuously updated as time progresses hence the term "**Rolling Demand**".

2.1.2.1 Calculating Rolling Demand

Each user set time period is split into smaller sub-periods (10 for V and I, 15 for kW). An average value for measurements taken every second during a sub-period are calculated for each parameter. The most recent 10 (15 for kW) sub-period averages are stored in memory as an array. An average of the data in each of these arrays is displayed as MD (rolling demand).

On power up (or after a brown-out) the sub-period array values are reset to zero. During the first full MD period the Rolling Demand value will accumulate as the zeroes are replaced with valid sub-period averages.

2.1.2.2 Peak Demand (kW, V and I Pk)

Peak MD readings are the maximum recorded values of corresponding Rolling Demand values.

Peak demand amps and kW readings may be used to determine the maximum load requirement of a system. They are often used to determine spare capacity in a supply system, supply plant requirement etc.

On power failure or brown-out Peak Demand values are automatically saved in non-volatile memory within the RailRTU. The memory requires no battery and will hold the value for up to 10 years in the absence of mains power.

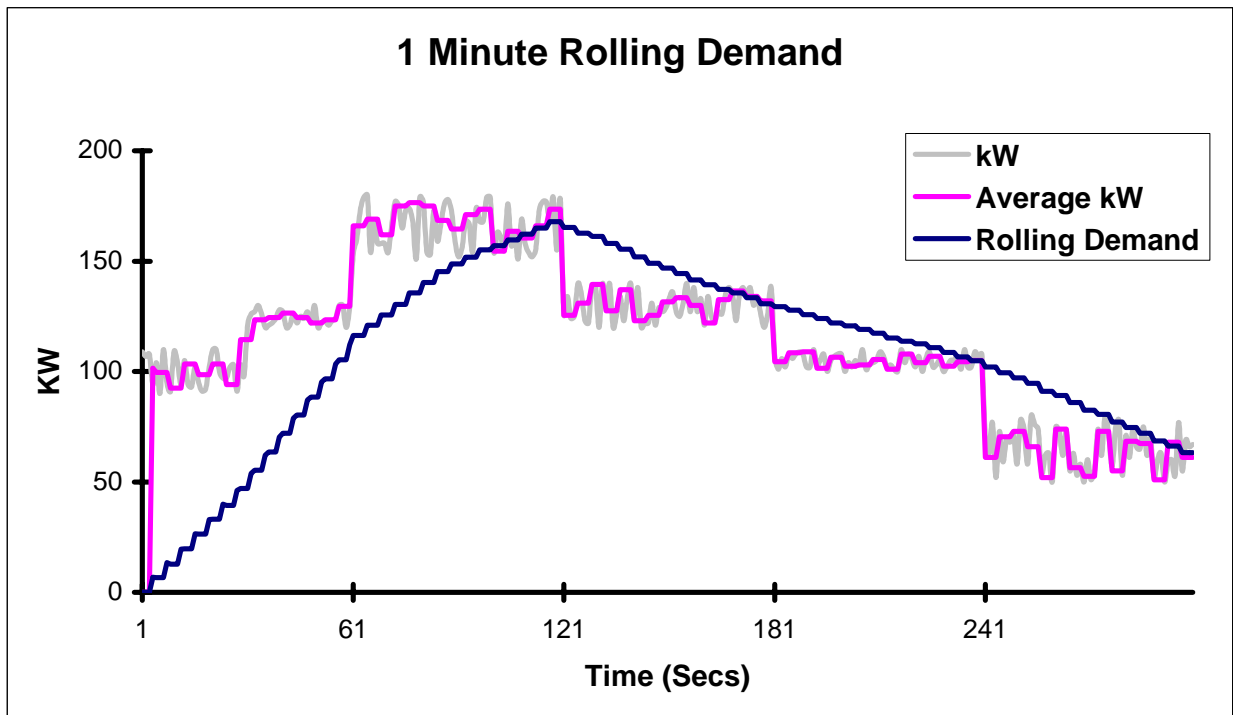

Figure 2-1 Graphical Example Of rolling kW Demand

Figure 2.1 above graphically illustrates Rolling Demand. Instantaneous kW is seen to change rapidly (calculated once a second) due to the nature of the load being measured. Step changes appear in the profile as loads are switched on/off.

The sub-period averages are shown updated every 4 seconds (15 periods for 1 min rolling demand). These follow the instantaneous kW curve closely but smooth out the peaks and troughs.

The Rolling Demand provides a “Trend Line” for instantaneous kW. There is a time lag between the instantaneous changes and the Rolling Demand due to the time taken to build a history of average readings.

Meter Operation

2.1.3 Percentage THD

Modern power systems are often required to drive non-linear loads such as motor controllers, computers etc. These non linear loads may cause waveform distortion of the currents and voltages in the system. This can lead to inefficiency or cause many problems such as motor over heating, leakage currents etc.

A distorted waveform is made up of the pure fundamental sine wave with a number of harmonics added to this. For example a current waveform could be made up of 100A at 50Hz, 10A at 150Hz, 15A at 200Hz etc. Badly distorted waveforms have a higher harmonic content.

The RailRTU provides a measure of the distortion, in each phase voltage and current waveform, as a percentage deviation from pure 50Hz or 60Hz sine waves. This is carried out using a Fast Fourier Transform (FFT) algorithm to accurately extract the fundamental sine wave from the total waveform. The 50Hz component is automatically detected for signals with frequencies in the range 45-55Hz and 60Hz is used for 55-65Hz.

The calculation is performed as follows :

$$\% \text{ THD} = \sqrt{\{(W_{\text{rms}}^2 - W_f^2) / W_{\text{rms}}^2\}} \times 100$$

Where :

W_{rms} is the RMS value of a total waveform

W_f is the RMS value of the 50Hz (or 60Hz) component of the waveform

Note: A Vr input greater than 5% of full scale is required for all THD calculations. THD for an individual input is not detected for signals less than 6% of full scale.

Display

The RailRTU is designed to operate as a remote transducer with no local display of measured parameters. Other products are available in the range which include an intelligent LCD display.

The display on the RailRTU is designed to aid commissioning and enables programming of serial communication parameters.

2.2 Baud/Address Display

A 2½ digit (00-199) 7 Segment LED display is used to show the RailRTU Modbus Address and serial communication baud rate (as kilo-baud).

Press the Δ key to select display of Modbus Address

Press the ∇ key to select display of Baud Rate

Two LED enunciators “**Addr**” and “**Baud**” indicate the value currently displayed.

2.3 Modbus Diagnostic LEDs

The RailRTU uses 3 LEDs to aid commissioning within a Modbus system. These indicators are also useful to check continued operation of the device.

The LEDs are intelligent indicators, which are illuminated under specific conditions as follows:

<i>Rx Cmd</i>	Illuminated when a valid host command is received, surrounded by RTU frame breaks (ref 4.3.2) with the correct Modbus address.
<i>Exception</i>	Illuminated when a Valid Command is received as above but an Exception Condition (ref 4.5.5) is detected.
<i>BUS ACTIVITY</i>	Illuminated whenever any data signal appears on the bus.

Meter Operation

2.4 Isolated Pulse Outputs

RailRTU meters incorporate two isolated pulse outputs. These outputs provide a simple interface to external systems such as building management centres etc.

Pulse outputs take the form of an isolated, normally-open, volt free contact pair. Each pulse is effectively a contact closure (low resistance) for a short period of time 't'.

Pulses occur at the end of every 'T' counts of the associated energy register. 'T' does not take into account the scaling (e.g. kWh) or decimal points of the register.

The pulse rate 'T' may be programmed independently for each output using the Modbus interface (ref section 4) or in programming mode (ref section 2.5). The actual energy associated with a single pulse depends on the user programmed CT and PT primary settings.

The Pulse ON time is scaled as 't' x 100ms and is factory set as 1 (100ms). This is recognised as the industry standard and is suitable for most external systems. If longer pulses are required 't' may be programmed using the Modbus interface (ref section 4). An example of a RailRTU set with 'T' = 5 and 't' = 1 and Energy scaled as 999999.9 kWh is shown below:

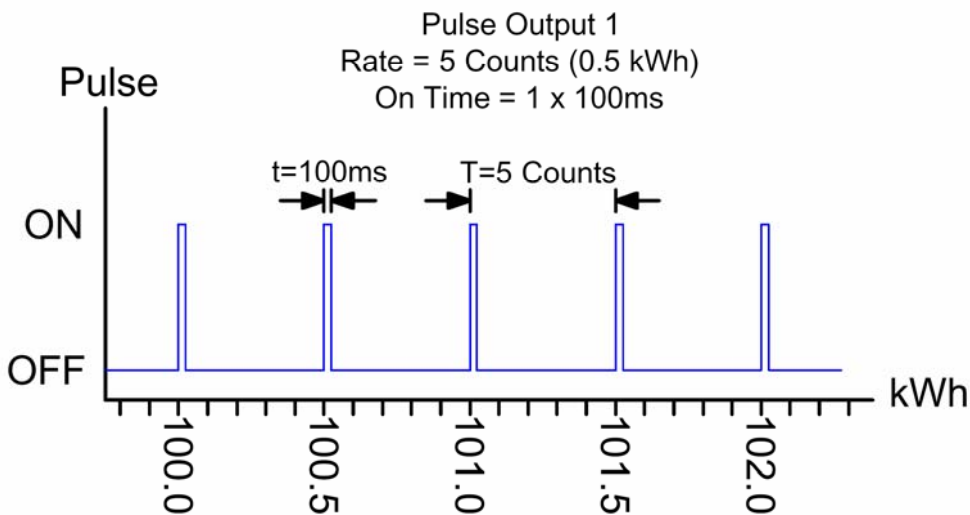

Figure 2.2 Example of Pulse Output scaling

Meter Operation

Connection of the Pulse outputs is shown in the diagram below. The switches shown are internal to the meter and are fully isolated at 2.5kV from the meters measurement circuit. The switches are isolated at 50V from each other.

External components, such as pull up resistors, may be required. For further information on connection refer to the documentation for the external system

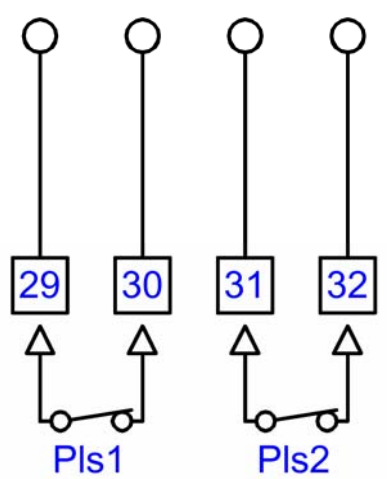

Figure 2.3 Pulse Output Connection

Meter Operation

2.5 Setting Baud/Address

The Modbus Address and Baud rate are stored in permanent memory in the RailRTU. These settings are held for a minimum of 10 years in the event of auxiliary power loss to the unit. These stored values may be changed by the user as part of commissioning the Modbus system.

Press the **Δ and ∇** keys **TOGETHER** and **HOLD** for 5 seconds.

The **Addr LED** will begin to **BLINK**. The Modbus Address may now be changed.

Press the **Δ key** to increase or the **∇ key** to reduce the Address as required.

Press the **Δ and ∇** keys **TOGETHER** and **HOLD** for 5 seconds.

The **Baud LED** will begin to **BLINK**. The Baud Rate (displayed in kilo-baud) may now be changed.

Press the **Δ key** to increase or the **∇ key** to reduce the baud rate as required.

Press the **Δ and ∇** keys **TOGETHER** and **HOLD** for 5 seconds to complete programming

3. Installation

3.1 Rail Mounting

The RailRTU is housed in an enclosure conforming to DIN standard 43880, 6 Modules wide (106mm). The unit is therefore compatible with a number of standard DIN distribution systems with 45mm cut-outs. The unit may be mounted by itself or alongside other standard units such as timers, circuit breakers etc. The RailRTU should be mounted on a symmetric 35mm DIN rail of minimum length 106mm.

3.2 CT Connections (I1-I3)

The RailRTU is designed for use with current transformers (CTs). Recommended types should conform to Class 1 per IEC 185. The secondary of the CT should be specified to suit the input rating defined on the meter label. Cables used for the current circuit should have a maximum conductor size of 4.0mm^2 and should be kept as short as possible to reduce cable losses loading the CT secondary.

CT Inputs to the meter are isolated from each other and all other parts of the circuit. This allows use on a wide variety of systems including those requiring common and/or earthed CT secondaries.

WARNING :

NEVER leave the secondary of a current transformer open circuit while a primary current flows. In this condition dangerous voltages may be produced at the secondary terminals.

Installation

3.3 Voltage Connections (Vn, V1-V3)

Cables used for the voltage measurement circuit should be insulated to a minimum of 600V AC and have a minimum current rating of 250mA. The maximum conductor size is 4.0mm².

External protection fuses are recommended for the voltage measurement inputs. These should be rated at 160mA maximum, Type F, and should be able to withstand voltages greater than the maximum input to the meter.

3.4 Auxiliary Mains Supply (L & N)

The RailRTU uses an isolated auxiliary mains supply separate from the voltage measurement inputs. This may be connected separately or in parallel with the measurement inputs providing the ratings detailed on the instrument label are not exceeded.

Separate connection of the auxiliary mains is required, for example, when :

- A suitable supply voltage is not available locally.
- Measurement voltages are expected to vary over a wide range
- A backup supply is required to maintain meter display

WARNING :

The auxiliary mains supply to one or more RailRTU units should incorporate appropriately rated safety fusing.

External fusing of the auxiliary supply is recommended, to protect the meter from damage during fault conditions. The fuse should be chosen to suit meter ratings as detailed on the instrument label. The fuse rupture current should be rated at 100mA for a single RailRTU. Type T fuses are recommended to prevent nuisance blowing during short term supply transients.

3.5 Connection Schematics

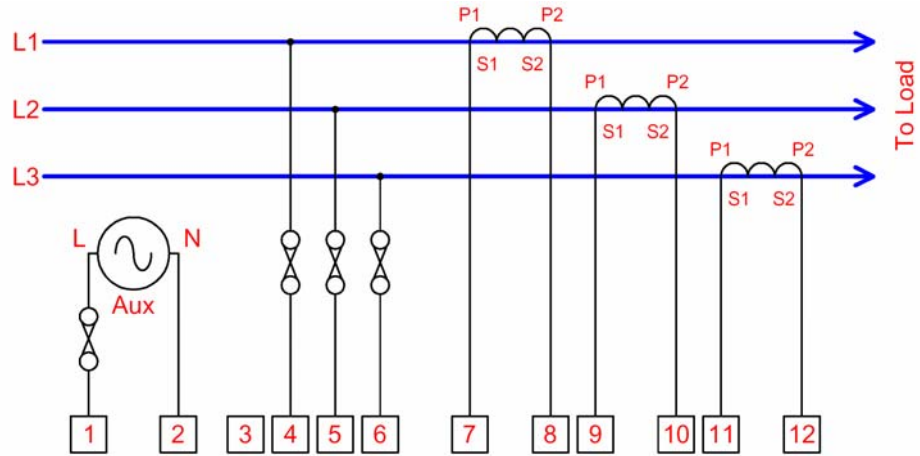

Figure 3-1 3-Phase 3-Wire (3CTs)

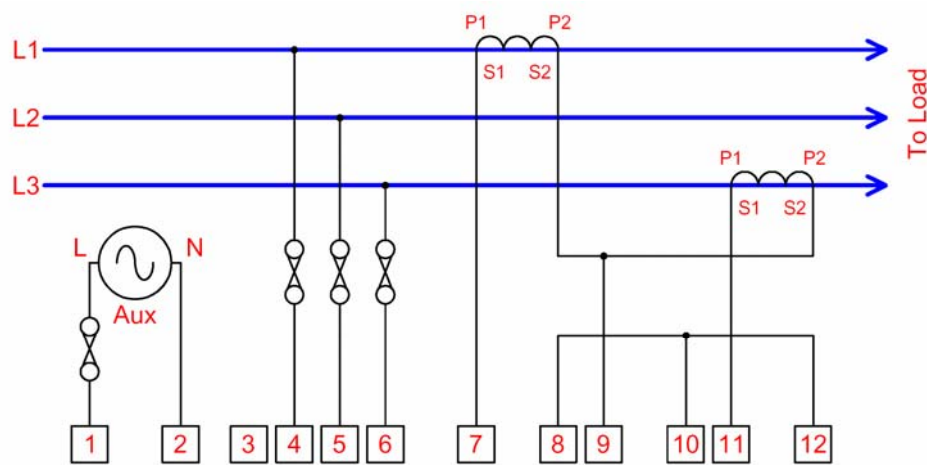

Figure 3-2 3-Phase 3-Wire (2CTs) ¹

Note 1 : 3-Phase 3-Wire (2CT) Connection is not suitable for Balance Current Measurements

Installation

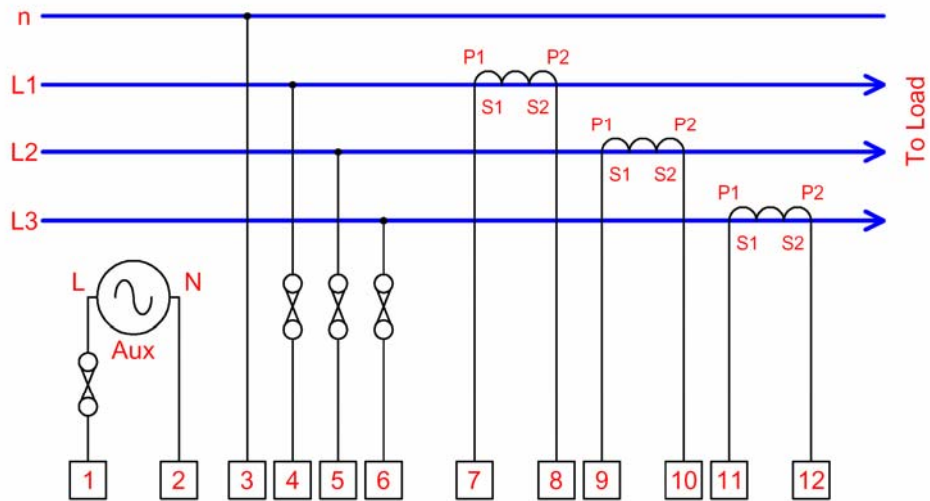

Figure 3-3 3-Phase 4-Wire

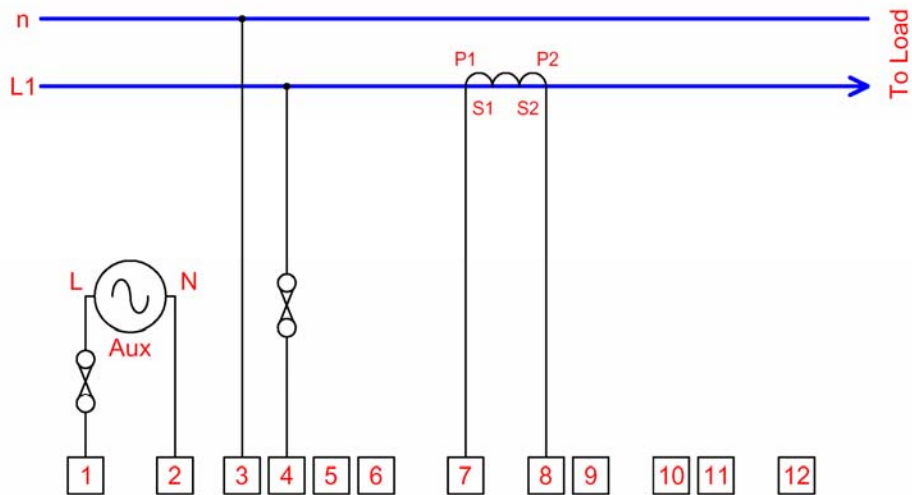

Figure 3-4 Single Phase

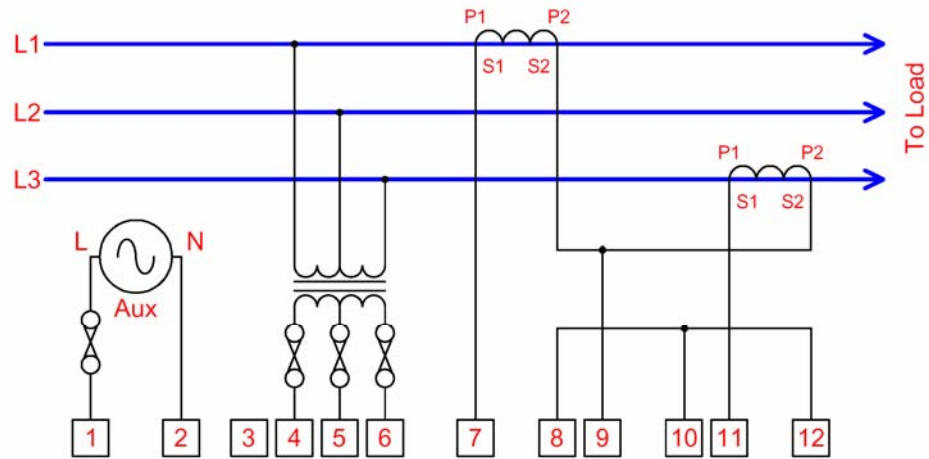

Figure 3-5 3 Phase 3 Wire Using Potential Transformers

4. Modbus Communication

4.1 Description

The RailRTU provides a two wire (half duplex) RS485 serial communications interface to external systems. This allows remote reading and programming of the meter by a host computer (e.g. PC).

The communication protocol used is a subset of Modicon's Modbus enabling use of standard 'off-the-shelf' software packages and connection to standard controllers.

4.1.1 Communication Address

Each RailRTU on a Modbus serial communication network must be assigned a unique address between 1 and 199. This is carried out in programming mode as described in Section 2.5. If two or more meters, connected in a multi-drop network have the same address, data on the network will be corrupted and communication will fail.

4.1.2 Data Format

The RailRTU uses a fixed data format for serial communications:

1 Start Bit	8 Data Bits	1 Stop Bit
-------------	-------------	------------

The 8 data bits are always transmitted least significant bit first. This data byte is binary coded.

The baud rate is programmable as **4800, 9600, or 19200 baud**. This is carried out in programming mode as described in Section 2.5

4.2 RS485

RS485 communication on the RailRTU enables connection of up to 128 meters on a single pair of wires (199 with repeaters). This pair is used for transmission and reception with each meter (and the host) automatically switching data direction. The host should be fitted with an RS485 driver (or converter) capable of operation in two wire mode (half duplex).

PC operation in RS485 two-wire mode usually requires software control of the data direction. This controls the line drivers connected to the bus at the host serial port. This direction control requires high speed operation and may be problematic under certain multi-tasking operating systems such as Windows. It is advisable to check with the software vendor before selecting software direction control as the mode of operation. If software data direction control is not suitable, RS232-RS485 converters are available for standard PCs, which carry out automatic hardware direction control. For more information on these contact your distributor.

Each Modbus serial transaction is preceded by a device address allowing the host to temporarily communicate with a specific meter on the bus. Certain commands allow the host to communicate with all meters simultaneously. These commands are known as **broadcasts** and use address 0.

4.2.1 RS485 Connection

4.2.1.1 Cable Selection

A dedicated, screened twisted pair cable is required to provide a basic RS485 connection. A second twisted pair may be used for 0V connection if required.

The cable should be chosen to suit the data rate and maximum length to be installed. The EIA RS-422/485-A standard provides curves that relate cable length to data rate for 24 AWG screened, twisted pair, telephone cable with a shunt capacitance of 50pf/m. For baud rates up to 19,200 the standard suggests a maximum length of 1200m for this type of cable. If other types of cable are to be used it is recommended that the cable supplier is consulted as to the suitability for use with RS485 to 19,200 baud.

Modbus Communication

4.2.1.2 Signal 0V and Cable Shield

A signal 0V termination is provided on each meter. Although RS485 does not strictly require a signal 0V, it is recommended this be connected as shown in the diagram below. This creates a known reference for the isolated RS485 system thereby reducing potential common mode errors in the meter's driver circuit.

A cable shield is used to attenuate noise picked up from external sources. This should be continuous, and cover as much of the signal pairs as possible. It is recommended that the shield should be connected to ground at the host only.

4.2.1.3 Terminating Resistors

In order to minimise signal errors due to noise over long cable lengths, terminating resistors may be fitted. These match the RS485 device impedance to that of the cable. Two 120 ohm resistors, one at the host port terminals and the other at the most remote meter terminals are recommended for this purpose.

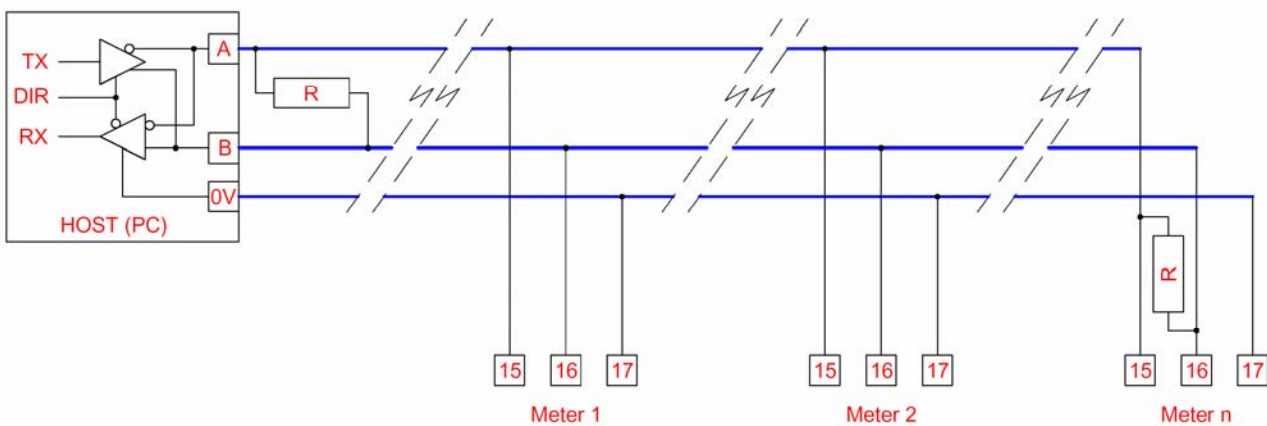

Figure 4-1 Basic RS485 Connection

4.2.1.4 Connection To Meters

The bus should be taken to meters at each location for termination, using the meter terminals as a loop in-out connection. The use of spurs should be avoided wherever possible.

Modbus Communication

4.3 Modbus Protocol

4.3.1 An Introduction To Modbus

A communication protocol defines a set of commands and data formats which will be recognised by all compatible equipment connected on a system. The protocol effectively forms a communication language.

The RailRTU utilises a subset of Modicon's 'Modbus' standard protocol. This protocol was originally developed for use by programmable logic controllers (PLCs). It defines a set of commands for reading and/or writing data to devices connected on the bus.

Modbus is a master-slave protocol with all transactions initiated by a single host (e.g. a PC). A single transaction commences with the host transmission of a command packet followed by a slave (RailRTU) reply after a short delay for processing the command.

Command packets consist of an address, a command identifier, data and a checksum for error detection. Each slave device continually monitors the bus looking for activity. Command packets are detected by all slaves but may be acted upon only by the device whose address matches that transmitted.

The host may transmit a **broadcast command**, which uses address 0 to contact all devices on the network. In this instance all slaves act on the command but none of them may reply. This type of command may be useful, for example, in synchronising energy register reset on all meters.

The full Modbus protocol consists of many commands and modes of operation to suit a variety of controllers and applications. The RailRTU utilises only a few commands and a single transmission mode to perform many functions relevant to metering.

4.3.2 RTU. Transmission Mode

The RTU (Remote Terminal Unit) mode is utilised by the RailRTU because it provides the most efficient throughput of data at any particular baud rate.

In RTU mode, the start and end of each message is marked by a silent period of at least 3.5 character periods (Approx. 3.5ms @ 9600 baud). This is shown in the RTU message frame in Figure 4-3 below.

START	ADDRESS	FUNCTION	DATA	CRC	END
SILENT PERIOD	8 BITS	8 BITS	n x 8 BITS	16 BITS	SILENT PERIOD

Figure 4-3 RTU Framing

The host (PC) initiates all transactions. Slave devices continuously monitor the network, looking for messages framed by silent periods. The first character detected, after a silent period, is assumed to be an address byte and is compared to the meters internal address (zero for broadcasts). An addressed slave reads the remainder of the message and acts upon it as required.

A slave tests the message to determine it's validity and uses the transmitted checksum (CRC) to detect communication errors. A slave will only act on valid messages, received without error, specifically addressed to it.

Modbus Communication

ADDRESS

Modbus defines a full set of slave addresses in the range 0-247. RailRTU devices may be assigned addresses in the range limited to 1-199. Address 0 is retained for broadcast commands which are handled by all slaves. When a slave responds to a command it places its own address in the reply message.

FUNCTION

The function code is a single byte telling the device what type of operation to perform. Valid Modbus codes are in the range 1-255 decimal but the RailRTU handles a subset of these as summarised below.

Function code	Operation	Broadcast
03	Read Multiple Registers	No
04	Read Multiple Registers	No
06	Preset A Single Register	Yes
08	Loop Back Diagnostic	No
16	Preset Multiple Registers	Yes

Figure 4-4 Function Code Summary

DATA FIELD

Data from the host contains additional information for the remote device specific to the command. For example the data field may specify which meter readings are required or new values for energy registers. Data from a slave may contain meter readings or other information requested by the host.

The size of the data field varies depending on command type and usage. The data format may also vary from one command to another to suit the application.

Instantaneous readings for example are transmitted as 2-byte Integers, whereas energy readings are formatted as 4-byte Long Integers. Data is always transmitted with the most significant byte first. Data formatting is described in more detail in the following sections.

4.3.3 CRC ERROR CHECKING

A 16 bit CRC (*Cyclic Redundancy Check*) field is tagged on to the end of all messages. This field is the result of a CRC calculation performed on the message contents. The CRC field is used by the host and receiving devices alike to determine the validity of the entire message string. A receiving device recalculates the CRC and compares it to the value contained in the message. A slave device ignores a message if the two values do not match.

Note

Use of the CRC is essential when communicating in noisy environments to reduce the effects of erroneous bit errors. The meter will not reply to commands with a CRC in error and the host should re-transmit the command after a pre-determined time-out period. If the host receives a string with a CRC in error the transaction should be re-initiated.

The CRC is calculated on all bytes of a message from the address to the last data byte inclusively. Each bit of the message is processed through the CRC calculation starting with the first bit of the address. The Modbus standard method of CRC calculation requires reversal of the data bytes as they are fed serially through the bit processing routines. A simpler method involves swapping the low and high order bytes of the CRC integer at the end of the calculation. This is shown in the following routine.

Modbus Communication

The calculation is performed as follows:

1. Load a 16 Bit register (“CRC Register”) with FFFF Hex. (All 1’s).
2. Exclusive-OR the first 8 Bits of the message with the low-order byte of the CRC register. Put the result in the CRC register.
3. Shift the CRC register one bit to the right (divide by 2), filling the MSB with a zero.
4. If the bit shifted out in 3 is a 1, Exclusive-OR the CRC register with the value A001 Hex.
5. Repeat steps 3 and 4 until 8 shifts have been performed and the bits tested. A single byte has thus been processed.
6. Repeat steps 2 to 5 using the next 8 bit byte of the message until all bytes have been processed.
7. The final contents of the CRC register is tagged on to the end of the message with the most significant byte first.
8. Swap the low and high order bytes of the integer result

An implementation of the CRC calculation in C code is shown below :

```
unsigned int check_sum(unsigned char *buff, char start, char bytes)
{
    char byte_cnt,bit_cnt;          /* loop counters */
    unsigned int crc_reg;           /* Result register */
    unsigned int CRCHi, CRCLO; /*Low and high order bytes of the crc*/

    crc_reg = 0xFFFF;              /* Set the CRC register to all 1's */

    /* Repeat for each byte of sub string */
    for(byte_cnt=start; byte_cnt<(bytes+start); byte_cnt++)
    {
        crc_reg = crc_reg ^ (unsigned int)buff[byte_cnt]; /*EXOR CRC & Next Byte*/

        /* Test each bit of the CRC */
        for(bit_cnt=0; bit_cnt<8; bit_cnt++)
        {
            if(crc_reg & 0x0001)
            {
                crc_reg = crc_reg >> 1; /* IF LSB=1 EXOR CRC with A001H */
                crc_reg = crc_reg ^ 0xA001; /* Then shift CRC toward LSB */
            }
            else crc_reg = crc_reg >> 1; /* ELSE Shift CRC towards LSB */
        }
    }
    CRCLO=crc_reg>>8; /*Swap the low and high order bytes of the crc result*/
    CRCHi=crc_reg<<8;
    crc_reg = CRCLO+CRCHi;
    return crc_reg;                /* Final CRC register Result */
}
```

Modbus Communication

4.4 RailRTU Data Tables

Data in the RailRTU is arranged in several tables for convenience. Individual tables contain like information. Table data may be read only (e.g. instantaneous readings) or read/write access (e.g. CT primary).

Data in each table is pointed to in a Modbus command by two consecutive data address bytes. The first byte defines the table number and the second byte the offset of the data in the table. For example, 'address 2 , 1' would access Table 2, Entry 1 (3-Phase kWh). The Modbus standard defines data addresses using a 16-bit integer. In the case of the RailRTU the high byte of this integer is represents the table number and the low byte the offset. A Modbus integer address may be calculated as:

$$\text{Modbus Data Address} = (256 \times \text{Table No}) + \text{Table Offset}$$

SIGNED INTEGER

Signed Integers are 16 bit values transmitted as two 8 bit bytes. The most significant byte is always transmitted first. These values vary in the range -32767 to +32767 although some registers have a limited range of acceptable values. The most significant bit defines the sign: 0=positive; 1=negative.

UNSIGNED INTEGER

Unsigned Integers are 16 bit values transmitted as two 8 bit bytes. The most significant byte is always transmitted first. These values vary in the range 0 to 65535 although some registers have a limited range of acceptable values.

UNSIGNED LONG INTEGERS (Unsigned Long)

Unsigned long integers are 32 bit values transmitted as four 8-bit bytes. The most significant byte is always transmitted first. These values vary in the range 0 to 4294967295 although energy registers in the RailRTU have a limited range, 0-9999999.

4.4.1 Table 2 Accumulated Energy Readings

Offset	Address	Contents	Format	Bytes	Words	Access
0	512	Energy Scale Hi	Unsigned Long	4	2	Read Only
1	513	Energy Scale Lo				
2	514	kWh Hi	Unsigned Long	4	2	Read/Write
3	515	kWh Lo				
4	516	kVAh Hi	Unsigned Long	4	2	Read/Write
5	517	kVAh Lo				
6	518	kvarh (Ind) Hi	Unsigned Long	4	2	Read/Write
7	519	kvarh (Ind) Lo				
8	520	kvarh (Cap) Hi	Unsigned Long	4	2	Read/Write
9	521	kvarh (Cap) Lo				

4.4.1.1 Energy Registers

Energy registers in a RailRTU are stored in Modbus Table 2 as unsigned long integers.

4.4.1.2 Writing to Energy Registers

Function 6 or 16 may be used to write to the energy registers in Table 2. Function 6 allows access to the upper and lower integers of the 4-byte long individually. Upper integers have a maximum write value of 0x0F preventing out of range data being sent to the RailRTU.

Function 16 may be used to access a number of long integers using a single command. This is most useful for setting all registers to 0 simultaneously. Valid commands must send an even number of integers (2 integers per long) starting at an even address in Table 2 (Start of a register). Failure to follow these basic rules will result in an exception response (ref. Section 4.5.5).

Modbus Communication

4.4.1.3 Energy Scaling

Energy readings from the RailRTU are stored as unsigned long integer values with no decimal point or legend (e.g. kWh or MWh). A single scaling factor is provided to enable conversion of the raw data to real numbers in basic unit form (Wh, VAh or varh). The scaling factor is a constant value calculated in the RailRTU as a function of CT and PT Primary programming. To convert raw data to real numbers:

$$E = L \times 10^{(K-3)}$$

Where:

- L** = Long Integer number
- K** = Energy Scaling Factor
- E** = Scaled Energy Result

Example:

If the meter is programmed with CT Primary = 50 Amps and PT Primary = 415V:

The Energy Scaling Factor would be transmitted as: K=5

Energy Registers would be transmitted as: 9999999

Wh would be calculated as $9999999 \times 10^{(5-3)} = 9999999 \times 100 = 999999900$ Wh

VAh would be calculated as $9999999 \times 10^{(5-3)} = 9999999 \times 100 = 999999900$ VAh

varh would be calculated as $9999999 \times 10^{(5-3)} = 9999999 \times 100 = 999999900$ varh

4.4.2 Table 11 Instantaneous Meter Values

Offset	Address	Contents	Format	Bytes	Words	Access
0	2816	kW 3-Ph	Signed Integer	2	1	Read Only ⁴
1	2817	kVA 3-Ph	Signed Integer	2	1	Read Only ⁴
2	2818	kvar 3-Ph	Signed Integer	2	1	Read Only ⁴
3	2819	PF 3-Ph	Signed Integer	2	1	Read Only
4	2820	Frequency	Signed Integer	2	1	Read Only
5	2821	Phase 1 Volts	Signed Integer	2	1	Read Only ²
6	2822	Phase 1 Amps	Signed Integer	2	1	Read Only ¹
7	2823	Phase 1 kW	Signed Integer	2	1	Read Only ⁴
8	2824	Phase 2 Volts	Signed Integer	2	1	Read Only ²
9	2825	Phase 2 Amps	Signed Integer	2	1	Read Only ¹
10	2826	Phase 2 kW	Signed Integer	2	1	Read Only ⁴
11	2827	Phase 3 Volts	Signed Integer	2	1	Read Only ²
12	2828	Phase 3 Amps	Signed Integer	2	1	Read Only ¹
13	2829	Phase 3 kW	Signed Integer	2	1	Read Only ⁴
14	2830	Phase 1 PF	Signed Integer	2	1	Read Only
15	2831	Phase 2 PF	Signed Integer	2	1	Read Only
16	2832	Phase 3 PF	Signed Integer	2	1	Read Only
17	2833	Ph1-Ph2 Volts	Signed Integer	2	1	Read Only ³
18	2834	Ph2-Ph3 Volts	Signed Integer	2	1	Read Only ³
19	2835	Ph3-Ph1 Volts	Signed Integer	2	1	Read Only ³
20	2836	Neutral Current	Signed Integer	2	1	Read Only ¹
21	2837	Amps Scale	Signed Integer	2	1	Read Only
22	2838	Ph Volts Scale	Signed Integer	2	1	Read Only
23	2839	Ln Volts Scale	Signed Integer	2	1	Read Only
24	2840	Power Scale	Signed Integer	2	1	Read Only

- Notes:**
1. Use 'Amps Scale' at Address 2837 to convert to real Amps.
 2. Use 'Ph Volts Scale' at Address 2838 to convert to real Volts.
 3. Use 'Ln Volts Scale' at Address 2839 to convert to real Volts.
 4. Use 'Power Scale' at Address 2840 to convert to real W, VA or var.

Modbus Communication

4.4.3 Table 12 Additional Instantaneous Values

Offset	Address	Contents	Format	Bytes	Words	Access
0	3072	Phase 1 kVA	Signed Int	2	1	Read ⁴
1	3073	Phase 2 kVA	Signed Int	2	1	Read ⁴
2	3074	Phase 3 kVA	Signed Int	2	1	Read ⁴
3	3075	Phase 1 kvar	Signed Int	2	1	Read ⁴
4	3076	Phase 2 kvar	Signed Int	2	1	Read ⁴
5	3077	Phase 3 kvar	Signed Int	2	1	Read ⁴

Notes: 4. Use 'Power Scale' at Address 2840 to convert to real W, VA or var.

4.4.4 Table 13 Peak Values

Offset	Address	Contents	Format	Bytes	Words	Access
0	3328	PK Hold I1	Signed Int	2	1	Read/Write ⁵
1	3329	PK Hold I2	Signed Int	2	1	Read/Write ⁵
2	3330	PK Hold I3	Signed Int	2	1	Read/Write ⁵
3	3331	PK Hold V1	Signed Int	2	1	Read/Write ⁶
4	3332	PK Hold V2	Signed Int	2	1	Read/Write ⁶
5	3333	PK Hold V3	Signed Int	2	1	Read/Write ⁶
6	3334	Peak kW MD	Signed Int	2	1	Read/Write ⁷
7	3335	MD Period	Signed Int	2	1	Read/Write
8	3336	kW MD	Signed Int	2	1	Read Only ⁷

Notes: 5. Use 'Amps Scale' at Addr 2837 to convert to real peak hold Amps.

6. Use 'Ph Volts Scale' at Addr 2838 to convert to real peak hold V.

7. Peak kW MD & MD are scaled as 3-Phase kW/10

4.4.4.1 Instantaneous/Peak Values

Instantaneous and peak measurements in a RailRTU are stored in Modbus Tables 11-13 as Signed integers. Negative values are used for per phase/system kvar and PF readings to represent capacitive loads. All other values will be returned as positive integers.

4.4.4.2 Scaling Instantaneous/Peak Values

Instantaneous readings from the RailRTU are provided as signed integer values with no decimal point or legend (e.g. kW or MW). Scaling factors are provided to enable conversion of the raw data to real numbers in basic unit form (amps, volts, watts, VA, or var). These scaling factors are constant values calculated in the RailRTU as a function of CT and PT Primary programming.

To convert raw data to real numbers:

$$R = I \times 10^{(K-3)}$$

Where:

- I** = Integer number
- K** = Relevant Scaling Factor
- R** = Real number result

Example:

If the meter is programmed with CT Primary = 50Amps and PT Primary = 415V:

Scaling factors would be as: I Scale=1, Vph Scale=2, VLL Scale=2, P Scale=4

Integer Values would be transmitted as: 5000, 2400, 4157 and 3600

Amps would be calculated as $5000 \times 10^{(1-3)} = 5000/100 = 50.00A$

Phase Volts would be calculated as $2400 \times 10^{(2-3)} = 2400/10 = 240.0V$

Line Volts would be calculated as $4157 \times 10^{(2-3)} = 4157/10 = 415.7V$

3-Ph Power would be calculated as $3600 \times 10^{(4-3)} = 3600 \times 10 = 36000W$

Power factors are transmitted from the meter in the range -1000 to 1000 representing PF magnitudes of 0.0 to 1.000 with negative values indicating a capacitive load.

Frequency is transmitted from the meter scaled by a factor of 10. For example a measured frequency of 50.0 would be transmitted as 500.

Modbus Communication

4.4.5 Table 14 Meter Set-up

Offset	Address	Contents	Format	Bytes	Words	Access
0	3584	CT Primary	unsigned Int	2	1	Read/Write
1	3585	PT Primary	unsigned Int	2	1	Read/Write
2	3586	Pulse 1 Rate	unsigned Int	2	1	Read/Write
3	3587	Pulse 2 Rate	unsigned Int	2	1	Read/Write
4	3588	Baud Rate	unsigned Int	2	1	Read/Write
5	3589	Modbus ID	unsigned Int	2	1	Read/Write
6	3590	Meter Model	unsigned Int	2	1	Read Only
7	3591	Meter Type	unsigned Int	2	1	Read Only
8	3592	Meter Software	unsigned Int	2	1	Read Only
9	3593	V/I MD Period	unsigned Int	2	1	Read/Write ⁸
10	3594	Pulse Period	unsigned Int	2	1	Read/Write ⁸

Notes: 8. These values may not be written using Command 16

4.4.5.1 Meter Set-up Values

Information regarding the RailRTU's configuration is available in Table 14 as unsigned integers.

- **CT Primary.** (5A - 6500A) CT Primary used to scale Amps and Power values
- **PT Primary.** (60V - 50000V) PT Primary used to scale Volts and Power values
- **Pulse 1 Rate.** (1 - 255) No. of counts of kWh register per pulse (if fitted).
- **Pulse 2 Rate.** (1 - 255) No. of counts of kvarh register per pulse (if fitted).
- **Baud Rate.** (48, 96 or 192) RS485 baud rates of 4800, 9600 or 19200.
- **Modbus ID** (1 – 199). Modbus Meter Address.
- **Meter Model** A constant identifying the product range (RailRTU=150).
- **Meter Type** (=4). Used for compatibility with MultiCube. (Equivalent to type 4)
- **Meter Software** RailRTU version (e.g. 0x0014 = Version 1.04).
- **V/I MD Period** (1-255) Time period (seconds/10) for Current and Voltage Demand. Eg. A value of 6 corresponds to a demand period of 60 seconds.
- **Pulse Period** Pulse On Time x100ms for Pulse outputs 1 and 2. Eg 3 = 300ms

- Table 15 Peak Current and Voltage Demand

Offset	Address	Contents	Format	Bytes	Words	Access
0	3840	Peak I1 MD	unsigned Int	2	1	Read/Write ⁵
1	3841	Peak I2 MD	unsigned Int	2	1	Read/Write ⁵
2	3842	Peak I3 MD	unsigned Int	2	1	Read/Write ⁵
3	3843	Peak V1 MD	unsigned Int	2	1	Read/Write ⁶
4	3844	Peak V2 MD	unsigned Int	2	1	Read/Write ⁶
5	3845	Peak V3 MD	unsigned Int	2	1	Read/Write ⁶

Notes: 5. Use 'Amps Scale' at Addr 2837 to convert to real Peak Amp Demand.

6. Use 'Ph Volts Scale' at Addr 2838 to convert to real Peak Volts Demand.

The peak values of rolling demand averages of currents and voltages are available in Table 15 as unsigned integers.

4.4.6 Table 16 Current and Voltage Demand

Offset	Address	Contents	Format	Bytes	Words	Access
0	4096	I1 Demand	unsigned Int	2	1	Read Only ⁵
1	4097	I2 Demand	unsigned Int	2	1	Read Only ⁵
2	4098	I3 Demand	unsigned Int	2	1	Read Only ⁵
3	4099	V1 Demand	unsigned Int	2	1	Read Only ⁶
4	4100	V2 Demand	unsigned Int	2	1	Read Only ⁶
5	4101	V3 Demand	unsigned Int	2	1	Read Only ⁶

Notes: 5. Use 'Amps Scale' at Addr 2837 to convert to real Amp Demand.

6. Use 'Ph Volts Scale' at Addr 2838 to convert to real Volts Demand.

The rolling demand averages of currents and voltages are available in Table 16 as unsigned integers.

Modbus Communication

4.4.7 Table 17 Current and Voltage Distortion

Offset	Address	Contents	Format	Bytes	Words	Access
0	4352	V1 % THD	unsigned Int	2	1	Read Only ⁹
1	4353	V2 % THD	unsigned Int	2	1	Read Only ⁹
2	4354	V3 % THD	unsigned Int	2	1	Read Only ⁹
3	4355	I1 % THD	unsigned Int	2	1	Read Only ⁹
4	4356	I2 % THD	unsigned Int	2	1	Read Only ⁹
5	4357	I3 % THD	unsigned Int	2	1	Read Only ⁹

Notes: 9. % THD readings are scaled x10. A value of 1000 represents 100.0%

4.5 RTU Commands

4.5.1 Function 04 (or 03) Read Multiple Registers

Description

This function allows a number of registers from a meter table to be read in a single operation. This command is commonly used to obtain instantaneous, energy or set-up data from the meter. This command is not available as a *broadcast* command as it requires a return data packet from the meter.

Host Request

	BYTE	EXAMPLE
METER ADDRESS	1	19H
FUNCTION	2	04H
TABLE NUMBER (Address High Byte)	3	0BH
TABLE OFFSET (Address Low Byte)	4	00H
No. OF WORDS (N) (High Byte)	5	00H
No. OF WORDS (N) (Low Byte)	6	03H
CHECKSUM (High Byte)	7	B1H
CHECKSUM (Low Byte)	8	F7H

The example above shows a read of 3 consecutive Integers from the Instantaneous Data Table 11(0BH), offset 0. The meter accessed has a Modbus ID of 25 (19H).

Modbus Communication

Meter Response

	BYTE	EXAMPLE
METER ADDRESS	1	19H
FUNCTION	2	04H
NUMBER OF BYTES (2N)	3	06H
DATA REGISTER 1 (High Byte)	4	02H
DATA REGISTER 1 (Low Byte)	5	3AH
DATA REGISTER 2 (High Byte)	6	07H
DATA REGISTER 2 (Low Byte)	7	5CH
DATA REGISTER N (High Byte)	8	07H
DATA REGISTER N (Low Byte)	9	02H
CHECKSUM (High Byte)	10	51H
CHECKSUM (Low Byte)	11	E3H

The example shows a reply of 6 bytes (3 Integers) as:

3-Ph kW = 570 (02 3A Hex)
3-Ph kVA = 1884 (07 5C Hex)
3-Ph kvar = 1794 (07 02 Hex)

4.5.2 Function 06 Preset a Single Register

Description

This function allows a single integer register in a meter table to be changed by the host. This command is commonly used to program meter parameters or to reset energy registers to zero. When broadcast (address=0) all meters on the network are addressed together but none reply.

Host Request

	BYTE	EXAMPLE
METER ADDRESS	1	19 H
FUNCTION	2	06 H
TABLE NUMBER (Address High Byte)	3	0E H
TABLE OFFSET (Address Low Byte)	4	00 H
DATA VALUE (High Byte)	5	00 H
DATA VALUE (Low Byte)	6	C8 H
CHECKSUM (High Byte)	7	89 H
CHECKSUM (Low Byte)	8	6C H

The example above shows a value of 200 (00H C8H) written to the CT Primary register (Data Table 14, offset 0). The meter accessed has a Modbus ID of 25 (19H).

Modbus Communication

Meter Response

	BYTE	EXAMPLE
METER ADDRESS	1	19 H
FUNCTION	2	06 H
TABLE NUMBER (Address High Byte)	3	0E H
TABLE OFFSET (Address Low Byte)	4	00 H
DATA VALUE (High Byte)	5	00 H
DATA VALUE (Low Byte)	6	C8 H
CHECKSUM (High Byte)	7	89 H
CHECKSUM (Low Byte)	8	6C H

The reply format is a copy of the command confirming its validity:

NOTE: This Modbus command is limited to writing 2-byte data only. Long Integer registers may be written but the meter automatically sets the upper bytes to zero.

4.5.3 Function 08 Loop Back Diagnostic

Description

This function provides a simple means of testing the communication network and detecting if a particular meter is present. This command is not available as a *broadcast* command as it requires a return data packet from the meter.

Host Request

	BYTE	EXAMPLE
METER ADDRESS	1	19 H
FUNCTION	2	08 H
DIAGNOSTIC CODE (High Byte)	3	00 H
DIAGNOSTIC CODE (Low Byte)	4	00 H
DIAGNOSTIC DATA (High Byte)	5	03 H
DIAGNOSTIC DATA (Low Byte)	6	E8 H
CHECKSUM (High Byte)	7	E3 H
CHECKSUM (Low Byte)	8	6D H

The example above shows a command with a Loop Back Code of 0 and Diagnostic Data of 1000 (03H E8H). The meter accessed has a Modbus ID of 25 (19H).

Modbus Communication

Meter Response

	BYTE	EXAMPLE
METER ADDRESS	1	19 H
FUNCTION	2	08 H
DIAGNOSTIC CODE (High Byte)	3	00 H
DIAGNOSTIC CODE (Low Byte)	4	00 H
DIAGNOSTIC DATA (High Byte)	5	03 H
DIAGNOSTIC DATA (Low Byte)	6	E8 H
CHECKSUM (High Byte)	7	E3 H
CHECKSUM (Low Byte)	8	6D H

The reply format is a copy of the command confirming its validity:

4.5.4 Function 16 Preset Multiple Registers

Description

This function allows a number of registers in a meter table to be set, by the host, in a single operation. When broadcast (address=0) all meters on the network are addressed together but none reply.

Host Request

	BYTE	EXAMPLE
METER ADDRESS	1	19 H
FUNCTION	2	10 H
TABLE NUMBER (Address High Byte)	3	0D H
TABLE OFFSET (Address Low Byte)	4	03 H
NUMBER OF DATA WORDS (N) (High Byte)	5	00 H
NUMBER OF DATA WORDS (N) (Low Byte)	6	03 H
NUMBER OF DATA BYTES (2N)	7	06 H
DATA BYTE 1	8	00 H
DATA BYTE 2	9	00 H
DATA BYTE 3	10	00 H
DATA BYTE 4	11	00 H
DATA BYTE 5	12	00 H
DATA BYTE 6	13	00 H
CHECKSUM (High Byte)	14	0C
CHECKSUM (Low Byte)	15	FB

The example above simultaneously writes 00 to all three peak hold voltage registers (V1 Peak Hold = Table 13, Offset 3). The meter accessed has a Modbus ID of 25 (19H).

Modbus Communication

Meter Response

	BYTE	EXAMPLE
METER ADDRESS	1	19 H
FUNCTION	2	10 H
TABLE NUMBER (Address High Byte)	3	0D H
TABLE OFFSET (Address Low Byte)	4	03 H
NUMBER OF DATA WORDS (High Byte)	5	00 H
NUMBER OF DATA WORDS (Low Byte)	6	03 H
CHECKSUM (High Byte)	7	71 H
CHECKSUM (Low Byte)	8	7C H

The reply confirms the data address and amount of data received.

4.5.5 Exception Responses

When a host sends a query to an individual meter on the network it expects a normal response. In fact one of four possible events may occur as a result of the query:

- ◇ If the RailRTU receives the message with no communication errors, and can handle the query it will reply with a normal response.
- ◇ If the RailRTU does not receive the message due to a communication failure, no response will be returned and the host will eventually time-out.
- ◇ If the RailRTU receives the message but detects a communication error via its CRC, no response will be returned and the host will time-out.
- ◇ If the RailRTU receives the query with no communication errors but cannot handle the query (out of range data or address) the response will be an **Exception Response** informing the host of the nature of the error.

An Exception Response differs from a normal response in its Function Code and Data Fields.

Exception Response

	BYTE	EXAMPLE
METER ADDRESS	1	19 H
FUNCTION	2	84 H
EXCEPTION CODE	3	02 H
CHECKSUM (High Byte)	4	42 H
CHECKSUM (Low Byte)	5	C6H

Modbus Communication

EXCEPTION FUNCTION CODE

All normal function types have a most significant bit of 0 (< 80 Hex). In an Exception Response the meter sets the MSB to 1 (adds 80H to the received Function Type). The Function can therefore be used by the host to detect an Exception Response.

DATA FIELD

In an Exception Response the data field is used only to return the type of error that occurred (**Exception Code**).

The RailRTU utilises the following Exception Codes:

Code	Meaning
1	Data out of range
2	Table and/or offset out of range for this function
3	Odd number of Integers written to Long Integer registers
9	Internal error

5. Specification

Inputs	
System	3-Phase 3 or 4 Wire Unbalanced Load
Voltage	Vb. 230 / 400 Volt. 3-Phase 3 or 4 Wire Vb. 63 / 110 Volt optional Vb. 120 / 208 Volt optional Vb. 277 / 480 Volt optional
Current	Ib 5 Amp from external current transformers (CTs) Ib 1 Amp optional Fully Isolated (2.5kV each phase)
Measurement Range Voltage Current Energy Registers	20% to 120% 0.5% to 120% 0 – 9999999 (7 digits)
Frequency Range Fundamental Harmonics	45 to 65Hz Up to 20th harmonic
Input Loading Voltage Current	Less than 0.1 VA per phase Less than 0.1 VA per phase
Overloads Voltage Current	x2 for 2 seconds maximum x40 for 1.0 seconds maximum

Auxiliary Supply	
Standard	230 Volt ±15%. 45-65Hz
Options	115 Volt ±15%. 45-65Hz. (Others to order)
Load	5 VA Maximum

Specification

Accuracy	
Phase Current	0.2% I _b (1.0% Rdg. 0.05 I _b ≤ I _{ph} ≤ 1.2 I _b) ±1 digit.
Neutral Current	0.6% I _b (2.0% Rdg. 0.05 I _b ≤ I _n ≤ 1.2 I _b) ±1 digit.
Phase Voltage	0.2% V _b (1.0% Rdg. 0.2 V _b ≤ V _{ph} ≤ 1.2 V _b) ±1 digit.
Line-Line Voltage	0.3% V _b (1.0% Rdg. 0.2 V _b ≤ V _{LL} ≤ 1.2 V _b) ±1 digit.
Phase Watts	0.4% FS (1.0% Rdg. 0.05FS ≤ P ≤ 1.2FS) ±1 digit.
Phase VA	0.6% FS (1.5% Rdg. 0.05FS ≤ Q ≤ 1.2FS) ±1 digit.
Phase var	0.8% FS (2.0% Rdg. 0.05FS ≤ S ≤ 1.2FS) ±1 digit.
Phase PF	± 0.2 Degrees
System Watts	0.6% FS (1.0% Rdg. 0.05FS ≤ P ≤ 1.2FS) ±1 digit.
System VA	1.0% FS (1.5% Rdg. 0.05FS ≤ Q ≤ 1.2FS) ±1 digit.
System var	1.5% FS (2.0% Rdg. 0.05FS ≤ S ≤ 1.2FS) ±1 digit.
System PF	± 0.2 Degrees
Frequency	±0.05Hz. 45Hz ≤ F ≤ 65Hz
% THD Amps	± 0.5% THD 0.05 I _b ≤ I _{ph} ≤ 1.2 I _b
% THD Volts	± 0.5% THD 0.2 V _b ≤ V _{ph} ≤ 1.2 V _b
Wh Register	Class 1.0 EN 61036
VAh Register	Class 2.0
varh Registers	Class 2.0 IEC 1268
Timebase	Better than 100ppm/ deg C

Display	
Display Type	2½ Digit 7 Segment Red LED for display of Baud/Address 3 Red Leds for communications diagnostics
Data Retention	10 years minimum Stores energy registers, user settings, and peaks

Serial Communications	
Bus	RS485 2 Wire (+ Common Recommended)
RX Loading	1/8 Unit load per meter (up to 247 Meters per bus)
TX Drive	Up to 32 Unit Loads
Protocol	Modbus RTU wit 16 bit CRC. (JBUS Compatible)
Baud Rate	User programmable 4800, 9600 or 19200.
Modbus ID	User programmable 1-199
Latency	Maximum time to reply 200ms (90% of replies in 100ms)
Max Data Packet	Any complete table of data (or part thereof)
Command Rate	New command accepted within 5ms of replying to previous

Digital (Pulse) Outputs	
Function	1 pulse / energy unit (Output #1=N Wh, Output #2=N varh)
Scaling	Settable 1-255 counts of associated register
Pulse Period	100ms. (2ms Rise, 2ms Fall) Programmable 100ms – 25.0s using Modbus Interface
Type	N/O Volt free contact. Optically isolated BiFET
Contacts	100mA AC/DC max, 100V AC/DC max
Isolation	2.5kV (50V #1 to #2)

Specification

General	
Temperature Operating Storage	-10 deg C to +65 deg C -25 deg C to +70 deg C
Environment	IP40
Humidity	<75% non-condensing

Mechanical	
Enclosure	DIN 42880 x 6 Modules ULV94-V-O
Dimensions	106mm x 90mm x 58mm (6 Modules wide)
Weight	Approx. 400g
DIN Rail	DIN EN 50022 106mm min. x 35mm (Symmetrical Top Hat)
Terminals	Rising Cage. 4.0mm ² cable max

Northern Design (Electronics) Ltd,
228 Bolton Road, Bradford,
West Yorkshire, BD3 0QW, England.

Telephone: +44 (0) 1274 729533

Fax: +44 (0) 1274 721074

Email: sales@ndmeter.co.uk

Or: support@ndmeter.co.uk

Copyright © Northern Design 2000

Mmm-YY Q K P