

H2095-03 E

- ★ Compact unit for switchboard front panel mounting with standard instrument dimensions of 96 x 96mm.
- ★ Quick installation by means of clamping fittings and plug-in terminal blocks for easy service.
- ★ Noise and radio interference immunity according to EN50081-1, EN50082-1, EN50081-2 and EN50082-2
- ★ Microprocessor-based controller

Function

The H2000 Engine Controller has been designed to take care of the complete control of a diesel engine. It provides control features for automatic or manual starting, monitoring and protection of the engine during start and operation. Simultaneously the status and faults are indicated on the front panel. The H2000 is a microprocessor-based controller, giving programmability of timers, relay functions and auxiliary inputs.

The unit includes a tacho-detector. It determines the engine revolutions for crank-disconnect, overspeed, and underspeed by the frequency of the generator voltage. Therefore an external tacho relay is not required. Additionally it is possible to use external contact signals for all three tacho levels.

Operation

AUTO / OFF / MAN selector switch

The rotary selector switch for AUTO / OFF / MAN. function is situated on the front panel of the H2000.

At MAN. the start sequence is set for 1 start attempt and start signal is only accepted from the push button on the front panel of the H2000.

At AUTO the start sequence is set for 3 start attempts and start signal is only accepted from the input terminal.

RESET (lamp test)

With the selector switch at OFF and activation of the START button, auto-stop and alarms are reset. All LEDs on the front panel of the controller are on at reset (lamp test).



Description

Power supply

Terminals 1 and 2 are the power supply terminals. Nominal voltage is 12V or 24V. However, the unit will accept voltage from 9V to 36V. A yellow LED on the front panel will indicate the controller receiving correct supply voltage.

Safety On

During the start phase, some alarms should be blocked. For this function the Safety On time delay is used. It is the delay between disconnecting of cranking and start of complete survey (when all survey inputs are active). The duration of this delay can be programmed.

The green LED with the description Safety On will be active after this time delay has expired.

Fail to start

The red LED is active when start sequence has expired without the engine running. Setting the change-over switch on the front to OFF and activating START makes reset.

Remote start

Terminal 3 is the input for the remote start signal. It activates the horn relay, the fuel relay and the crank relay.

This input is active when the selector switch is in AUTO position.

Remote stop

Terminal 4 is the input for the remote stop signal. It will deactivate the fuel and the crank relay. This input is enabled when the selector switch is in AUTO position.

Low lubrication oil pressure

Terminal 5 is the input terminal for the low oil pressure signal. This input will always activate auto-stop. It is enabled after the Safety On timer has expired.

The red LED is active when low oil pressure input signal is received and the input terminal is active. Setting the change-over switch on the front to OFF and activating START makes reset.

High water temperature

Terminal 6 is the input terminal for the high engine temperature signal. This input will always activate auto-stop. It is enabled after the Safety On timer has expired.

The red LED is active when high water temperature input signal is received and the input terminal is active.

Setting the change-over switch on the front to OFF and activating START makes reset.

Battery

Terminal 7 is the input for the D+ signal from the battery charger. This input can be programmed to activate the alarm or auto-stop relay.

The red LED is active when the battery charger is not charging. Setting the change-over switch on the front to OFF and activating START makes reset.

When programmed to alarm only, reset can be performed in AUTO by activating the START button.

Aux 1

Terminal 8 is the input terminal for the Aux 1 signal. It can be enabled constantly or after the Safety On timer has expired. This input can be programmed to activate the auto-stop relay and/or the auxiliary relay and/or the alarm relay.

When this input receives a signal and is enabled, a red LED on the front panel will be active.

Setting the change-over switch on the front to OFF and activating START makes reset.

When programmed to alarm only, reset can be performed in AUTO by activating the START button.

Aux 2

Terminal 9 is the input terminal for the Aux 2 signal. It can be enabled constantly or after the Safety On timer has expired. This input can be programmed to activate the auto-stop relay and/or the auxiliary relay and/or the alarm relay.

When this input receives a signal and is enabled, a red LED on the front panel will be active.

Setting the change-over switch on the front to OFF and activating START makes reset.

When programmed to alarm only, reset can be performed in AUTO by activating the START button.

Aux 3

Terminal 10 is the input terminal for the Aux 3 signal. It can be enabled constantly or after the Safety On timer has expired. This input can be programmed to activate the auto-stop relay and/or the auxiliary relay and/or the alarm relay.

When this input receives a signal and is enabled, a red LED on the front panel will be active.

Setting the change-over switch on the front to OFF and activating START makes reset.

When programmed to alarm only, reset can be performed in AUTO by activating the START button.

Crank disconnect

Terminal 11 is input for an external signal indicating that the engine has reached the crank disconnect rpm. It will disconnect the crank relay. Enabled in MAN. or AUTO mode.

Underspeed

Terminal 12 is the input terminal for the underspeed signal. It can be programmed to activate the alarm or the auto-stop relay.

The red LED on the front panel will be active, in case underspeed rpm level has been obtained.

If this signal is completely lost while the engine is running, the LED on the front panel will flash and shutdown will be activated.

Setting the change-over switch on the front to OFF and activating START makes reset.

In case an external tacho-relay with two levels only is in use, terminals 11 and 12 must be bridged.

Overspeed

Terminal 13 is the input terminal for the overspeed signal. It will always activate the auto-stop relay.

The red LED on the front panel will be active, in case overspeed rpm level has been reached.

Setting the change-over switch on the front to OFF and activating START makes reset.

Acoustic alarm

When activating START, the horn relay is activated in case tacho frequency is below crank disconnect level. It will be active until the start sequence has expired or a stop signal is received. Start sequence will be delayed by the acoustic alarm-timer. The timer can be programmed to 0, 5, 7 or 10secs.

The green LED on the front panel will

flash when the timer has not expired and light constantly when the start sequence is initiated.

Tacho frequency

Terminals 14 and 15 are inputs of the internal tacho-voltage detection relay. This input is enabled in MAN. or AUTO mode. If the rpm increases above 115% of nominal rpm, shutdown will be activated.

Underspeed alarm is activated if the rpm decreases below 90% of nominal rpm. Alarm or automatic shutdown can be programmed for this case. If the rpm decreases below 40% of nominal rpm, shutdown will be activated.

Horn relay

Terminals 16-18 are the outputs of the change-over contact of the horn relay.

Auto-stop relay

Terminals 19-21 are the outputs of the change-over contact of the auto-stop relay.

Alarm relay

Terminals 22-24 are the outputs of the change-over contact of the alarm relay.

Auxiliary relay

Terminals 25-27 are the outputs of the change-over contact of the auxiliary relay.

Crank relay

Terminal 28 is the output to the crank relay.

Emergency stop / power supply for crank and fuel relay

Terminal 29 is the input for the supply voltage for both crank and fuel relay. An external emergency stop should disconnect the supply voltage on this terminal.

The red LED is active when the supply voltage on this terminal is lost or the controller is in auto-stop with display of failure.

Setting the change-over switch on the front to OFF and activating START makes reset.

Fuel relay

Terminal 30 is the output to the fuel relay.

Programming

On the backside of the unit there are 24 programming switches. These switches are used for programming of following functions:

- Acoustic alarm time before crank : 0 – 5 – 7 – 10 secs
- Start time : 5 – 7 – 10 – 15 secs
- Start pause : 5 – 7 – 10 – 15 secs
- Tacho frequency : 50 / 60 Hz. nominal
- Safety On : 5 – 7 – 10 – 15 secs
- Underspeed : Alarm or auto-stop
- Battery : Alarm or auto-stop
- Acoustic alarm relay : Normally de-activated
- Auto-stop relay : Normally de-activated
- Alarm relay : Normally de-activated or normally activated
- Aux. relay : Normally de-activated
- Aux 1, Aux 2 and Aux 3 : Alarm or auto-stop
Constantly active or active after "Safety On" period
Connection possible to auto-stop relay, alarm relay and aux.-relay

In- and output terminals

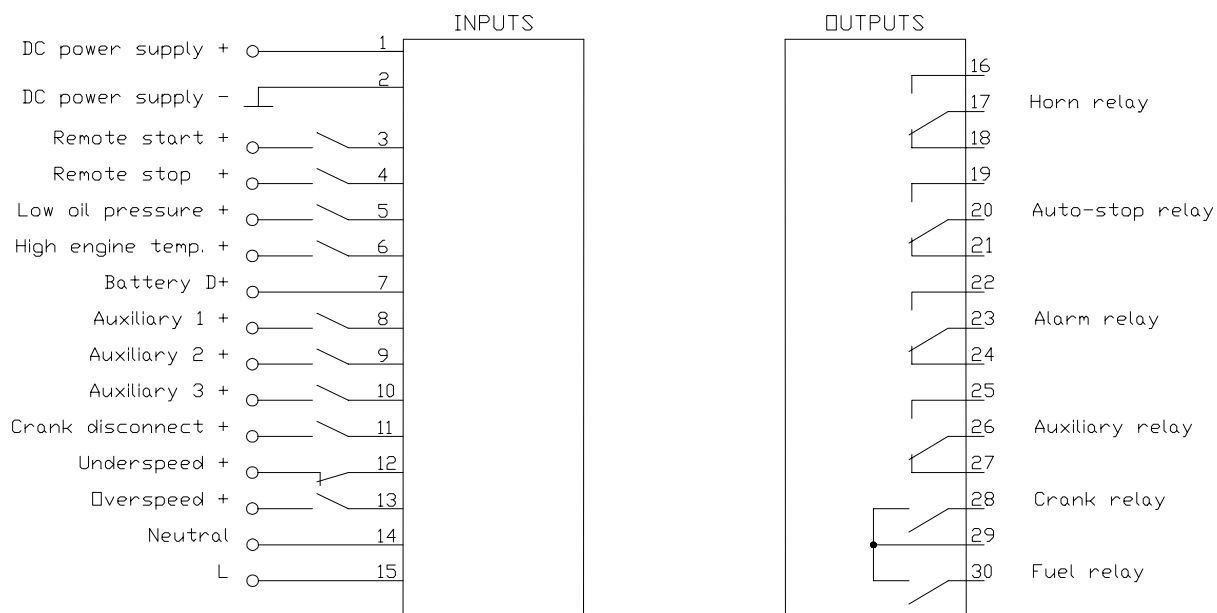

Specifications:

Voltage Supply	: 9V - 36V DC
Frequency	: 45 - 65
DC signal inputs	: Voltage range: 9-36V DC (must not exceed supply voltage) td (delay): 0.2sec Load: 4.7Kw internal pull down
Battery D+ input	: Voltage range : 9-36V DC (must not exceed supply voltage) td (delay): 0.2sec Load: 470w internal pull up
Tacho input	: Voltage range: 5-300V AC rms Power cons: 1.1VA typ. Fre- quency: 50Hz nom. or 60Hz nom. program- mable
Contact rating	: Crank and fuel relay: AC : 250V 16A 4000VA DC : 28V 16A 450W (36V 5A 180W) Auto-stop/ horn/ alarm/ aux.: AC : 250V 8A 2000VA DC : 28V 8A 225W (36V 5A 180W)
Ambient temp. range	: -20 to +70°C.
Humidity	: 95% relative humidity at 40°C (not condens- ing)
Shock	: 4g _{rms}
Height	: Max. 3050m (10.000ft) altitude above sea level
Dimensions	: 96 x 96 x 125mm
Cut out	: 92 x 92mm
Weight	: 0.525kg
EMC	: CE according to EN50081-1, EN50082-1, EN50081-2, EN50082-2
Protection	: Front IP54 Rear IP20

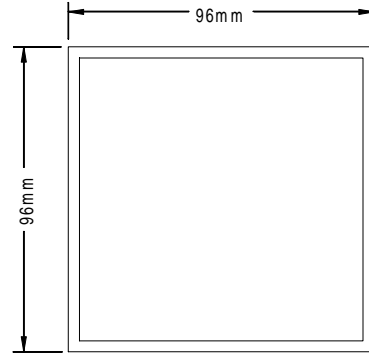

Cut out 92 x 92mm

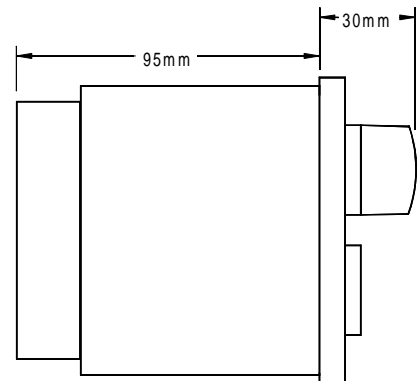

95-91

Options

Serial communication:

The controller has external connection possibility for serial communication on 3 conductors.

The controller has internal connection possibility for hardware for optional RS232, RS485 and MODBUS communication.