

MEASURING TRANSDUCERS

INTRODUCTION

Convert any electrical measuring signal (A, V, Hz, ϕ , W, Wh, var, varh) into a DC current or voltage signal. Used in plants or other installations where telemetering and data centralization is necessary, they allow the location of central control desk, data processor or computer, to remote distance from one or several measuring devices, as shown in the following example:

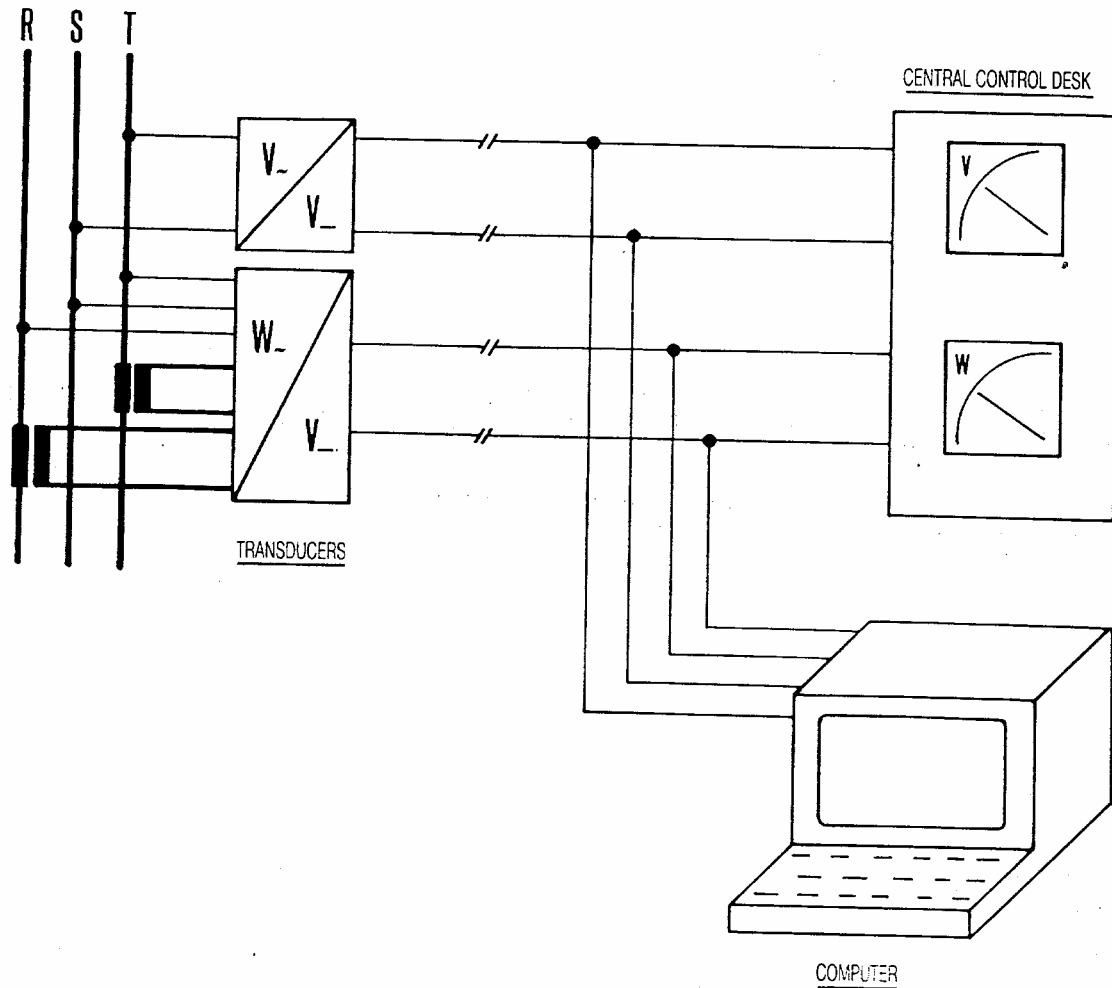

Advantages:

- High accuracy and reliability.
- Easy signal transmission by small cross section wires or screened cable
- Possibility of data processing by computer
- Low input burden
- Cost saving in equipment and installation
- Standard outputs reducing stock keeping cost

TYPES

AT – Panel mounted frame-retardant molded case to be mounted by means of two screws or to DIN-rail.

AR – Plug-in modules for 19” module-mounting rack.

Both series have the following versions according to the input and output values of the transducer:

STANDARD

On these transducers the output signal zero, correspond to the input signal zero.

V_n (V)	0	220
I_o (mA)	0	20

LIVE ZERO

Are the transducers where input signal zero corresponds to 20% of the output signal.

V_n (V)	0	220
I_o (mA)	4	20

SUPPRESSED ZERO

Are those transducers, which the output signal zero, corresponds to a fixed input value.

V_n (V)	80	220
I_o (mA)	0	20

GENERAL FEATURES

STANDARDS

IEC 668-1 (General)

IEC 255-4 and 5 (Protections)

AT-SERIES

Permissible overload ratings

Voltage 1.2 Vn continuous
2 Vn 10Sec.

Current 2 In continuous
10In 10Sec
40In 2Sec

Ripple <0.3%

Response time <150ms (0-90% of the output signal)

Protections:

Dielectric test: 2kV r.m.s. for 1 min.

Impulse voltage withstand test: 5kV – 1.2/50µS

High frequency disturbance test: 2.5kV, 1MHz

Working temperature range: 10°F - 140°F / -10°C - +60°C

Case protection: IP20

Terminal protection: IP10

Mounting details:

- 1- Standard panel mounting by M4 or M5 screws.
- 2- To 50022/35 DIN EN rail

DIMENSIONS (in millimeters)

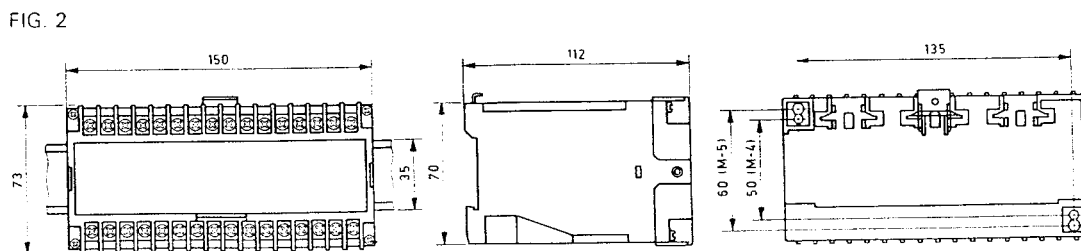
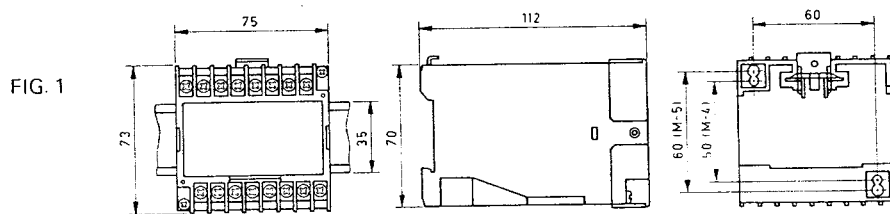

AR SREIES

Designed in 3U "EUROCARD" PCB (100x160mm) to be plugged-in standard 19" racks according to DIN 41494. Racks are considered as divided in 84T of 5.08mm each. The dimensions of the plug-in modules are always multiple of 1T or 5.08mm.

	Current Multiplying factor	Voltage Multiplying factor	Numbers of applications	Duration of each application of excessive input's	Interval between successive applications
Current	2 10	- -	10 5	10S 3S	10S 5Min
Voltage, frequency	-	1.5	10	10S	10S
Power (active, reactive)	1	1.5	-	10S	10S
Phase angle	10	1	5	3S	5Min

Ripple < 0.3%

Response time < 150ms (0-90% of the output signal)

Protections

Dielectric test: 2kV r.m.s. for 1 min.

Impulse voltage withstand test: 5kV – 1.2/50µS

High frequency disturbance test: 2.5kV, 1MHz

Working temperature range: 10°F - 140°F / -10°C - +60°C

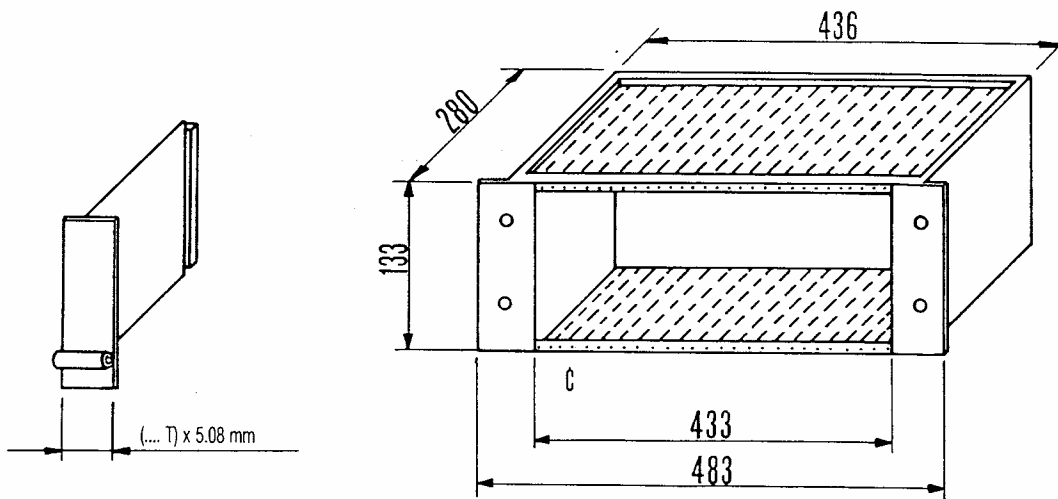

Input/output connectors comply with DIN 41612. Current circuits have an extra built-in contact shorting the secondary of the current transformers before the connection to the transducer is interrupted.

The main advantages of this series with respect to the conventional AT series are:

- Small space requirement
- Possibility of changing the plug-in modules during operation.

The transducers are available either as separate modules or as complete sets in 19" racks totally wired according to the user's requirements.

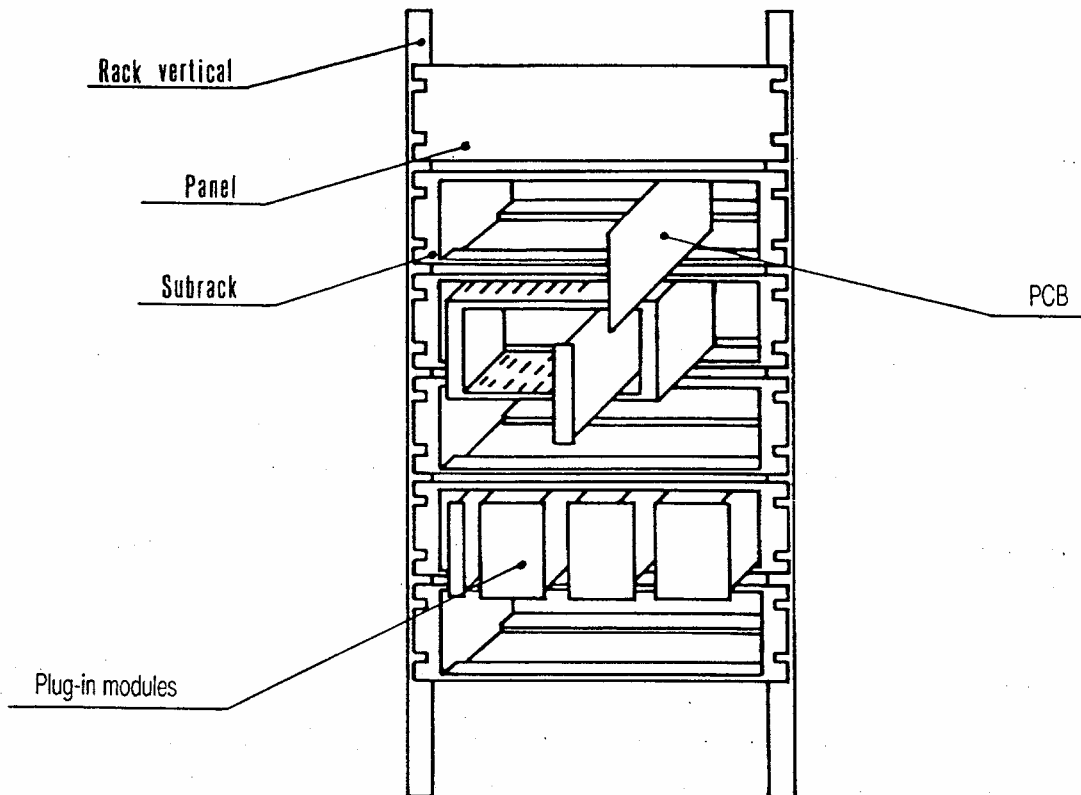

CURRENT TRANSDUCERS

ATI – ARI

Convert an AC current signal into a lower DC current signal (mA), being the output current proportional to the value of the AC input

Connection Diagram

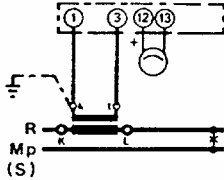

ATIa – ARIa

Converts an AC current signal into a proportional DC current or voltage signal. This type of transducers shall be used instead of the ATI type, when the following options are required:

- Live zero output
- Output in volts
- Output current to be proportional to the input from 0%

Auxiliary supply required

Connection Diagram

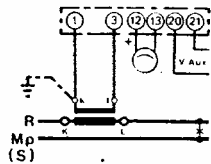

ATIca – ARIca

Converts a DC current signal into a DC current or voltage signal, being the output proportional to the input.

Input/Output isolation

Auxiliary supply required

Connection Diagram

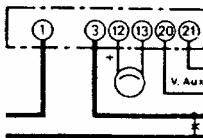

TECHNICAL DATA	AC CURRENT				DC CURRENT	
Type	ATI	ARI	ATIa	ARIa	ATIca	ARICA
Dimensions	Fig 1	8T	Fig 1	8T	Fig 1	8T

INPUT

Nominal value (In)	1A or 5A	1A or 5A	100 μ A to 5A (*)
Measuring range	0.2 to 1.2 In	0 to 1.2 In	0-1.2 In or -1.2 to +1.2 In
Frequency	50 to 60 Hz	50 to 60 Hz	-
Frequency coefficient 400-400Hz	0.003%/Hz	0.001%/Hz	-
Burden	1.2VA	0.4VA	In x 60mV

OUTPUT

Current standard output Load max. resistance	0-1mA 0-5mA 0-10mA	0-1mA 0-5mA 0-10mA	0-1mA or \pm 1mA 0-5mA or \pm 5mA 0-10mA or \pm 10mA
Ro (k Ω)= 12V/Lo (mA)	0-20mA	0-20mA 4-20mA	0-20mA or \pm 20mA 4-20mA
Voltage standard output- - Load min. resistance	--	0-1V > 1k Ω 0-5V > 1k Ω 0-10V > 4k Ω 1-5V > 1k Ω 2-10V > 4k Ω	0-1V or \pm 1V > 1k Ω 0-5V or \pm 5V > 1k Ω 0-10V or \pm 10V > 4k Ω 1-5V > 1k Ω 2-10V > 4k Ω
Max. output voltage under open circuit	30V	27V	17V
Saturation limit	1.5Lo	1.5Lo or 1.5Vo	1.5Lo or 1.5Vo

TRANSFER

Curves	A	A-B-C-D	A-B-C-D-E-F
Class (Accuracy %)	0.5	0.5	0.5
Linearity error	0.1%	0.1%	0.1%

AUXILIARY SUPPLY

AC Voltage	Not required	100, 110, 220, 380, 440V \pm 20%
Burden	-	3VA
DC Voltage	Not required	12, 24, 48, 110V \pm 20%
Burden	-	3W

AMBIENT CONDITIONS

Temperature coefficient (0 to 60 $^{\circ}$ C)	0.02%/ $^{\circ}$ C	0.01%/ $^{\circ}$ C	0.01%/ $^{\circ}$ C
---	---------------------	---------------------	---------------------

ORDERING DETAILS

ATI/ARI	ATIa/ARIa	ATIca/ARICA
Input Nominal Current	Input Nominal Current	Input Nominal Current
Output Nominal Current	Output Nominal Voltage/Current	Output Nominal Voltage/Current
	Auxiliary Supply	Auxiliary Supply

VOLTAGE TRANSDUCERS

ATU – ARU

Convert an AC voltage signal into a lower DC current signal.

Connection Diagram

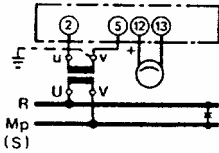

ATUa – ARUa

Converts an AC voltage signal into a proportional DC current or voltage signal. This type of transducers shall be used instead of the ATI type, when the following options are required:

- Live zero output
- Output in volts
- Output current to be proportional to the input from 0%

Auxiliary supply required

Connection Diagram

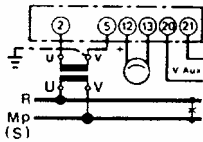

ATUca – ARUca

Converts a DC voltage signal into a DC current or voltage signal, being the output proportional to the input.

Input/Output isolation

Auxiliary supply required

Connection Diagram

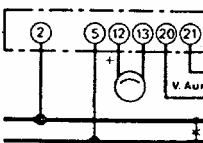

TECHNICAL DATA	AC VOLTAGE				DC VOLTAGE	
Type	ATU	ARU	ATUa	ARUa	ATUca	ARUca
Dimensions	Fig 1	8T	Fig 1	8T	Fig 1	8T

INPUT

Nominal value (Vn)	100,110,220,380,440V	100,110,220,380,440V	10mV to 440V (*)
Measuring range	0.4 to 1.2 Vn	0 to 1.2 Vn	0-1.2 Vn or -1.2 to +1.2 Vn
Frequency	50 to 60 Hz	50 to 60 Hz	-
Frequency coefficient 400-400Hz	0.001%/Hz	0.001%/Hz	-
Burden	1.2VA	0.5VA	Vn x 1mA

OUTPUT

Current standard output Load max. resistance	0-1mA 0-5mA 0-10mA	0-1mA 0-5mA 0-10mA	0-1mA or ±1mA 0-5mA or ±5mA 0-10mA or ±10mA
Ro (kΩ)= 12V/Lo (mA)	0-20mA	0-20mA 4-20mA	0-20mA or ±20mA 4-20mA
Voltage standard output- - Load min. resistance	--	0-1V > 1kΩ 0-5V > 1kΩ 0-10V > 4kΩ 1-5V > 1kΩ 2-10V > 4kΩ	0-1V or ±1V > 1kΩ 0-5V or ±5V > 1kΩ 0-10V or ±10V > 4kΩ 1-5V > 1kΩ 2-10V > 4kΩ
Max. output voltage under open circuit	30V	27V	17V
Saturation limit	1.5Lo	1.5Lo or 1.5Vo	1.5Lo or 1.5Vo

TRANSFER

Curves	A	A-B-C-D	A-B-C-D-E-F
Class (Accuracy %)	0.5	0.5	0.5
Linearity error	0.1%	0.1%	0.1%

AUXILIARY SUPPLY

AC Voltage	Not required	100, 110, 220, 380, 440V ±20%
Burden	-	3VA
DC Voltage	Not required	12, 24, 48, 110V ±20%
Burden	-	3W

AMBIENT CONDITIONS

Temperature coefficient (0 to 60°C)	0.006%/°C	0.001%/°C	0.01%/°C
--	-----------	-----------	----------

ORDERING DETAILS

ATU/ARU	ATUa/ARUa	ATUca/ARUca
Input Nominal Current	Input Nominal Current	Input Nominal Current
Output Nominal Current	Output Nominal Voltage/Current	Output Nominal Voltage/Current
	Auxiliary Supply	Auxiliary Supply

FREQUENCY TRANSDUCERS

ATF – ARF

Convert the frequency of an alternating signal into a proportional DC current or voltage signal. Auxiliary supply is not required

Connection Diagram

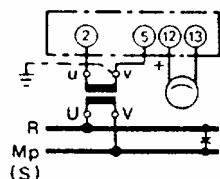

TECHNICAL DATA	FREQUENCY	
	Type	ATF
Dimensions	Fig 1	8T

INPUT

Nominal value (Vn)	100,110,220,380,440V $\pm 20\%$
Nominal value (Hz)	45 – 55 Hz; 45 – 65 Hz 55 – 65 Hz; 380 – 420 Hz
Burden	3VA

OUTPUT

Current standard output	0-1mA
Load max. resistance	0-5mA 0-10mA
Ro (k Ω)= 12V/Lo (mA)	0-20mA 4-20mA
Voltage standard output- - Load min. resistance	0-1V > 1k Ω 0-5V > 1k Ω 0-10V > 4k Ω 1-5V > 1k Ω 2-10V > 4k Ω
Max. output voltage under open circuit	27V
Saturation limit	1.5Lo or 1.5Vo

TRANSFER

Curves	B-D
Class (Accuracy %)	0.2
Linearity error	0.05%

AMBIENT CONDITIONS

Temperature coefficient (0 to 60°C)	0.01%/°C
--	----------

ORDERING DETAILS

Input Nominal Current
Output Nominal Current

PHASE ANGLE TRANSDUCERS

ATA – ARA

Convert the phase angle between current and voltage in a single-phase system, into a proportional DC current or voltage signal.

Connection Diagram

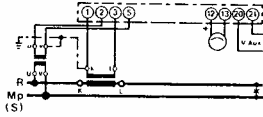

ATAI – ARAI

Converts the phase angle between current and voltage in a three-phase balanced system, into a proportional DC current or voltage signal.

Connection Diagram

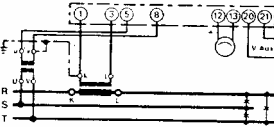

ATAu – ARTu

Converts the phase angle between two voltages into a proportional DC current or voltage.

Connection Diagram

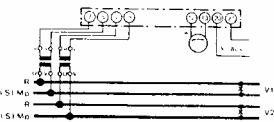

TECHNICAL DATA	VOLTAGE - CURRENT				VOLTAGE- VOLTAGE	
	ATA	ARA	ATAI	ARAI	ATAu	ARAU
Type	Fig 2	8T	Fig 2	8T	Fig 2	8T
Dimensions	Fig 2	8T	Fig 2	8T	Fig 2	8T

INPUT

Nominal value (Vn)	100,110,220,380,440V					
Nominal value (In)	1 or 5A (0.2 to 1.2In)		1 or 5A (0.2 to 1.2In)		--	
Measuring range	-60° - 0 - +60° (Cos.φ 0.5 CAP -1-0.5 IND) For other values please consult					
Frequency	50 to 60 Hz					
Voltage burden	0.5VA					
Current burden	0.2VA		0.2VA		--	

OUTPUT

Current standard output Load max. resistance	0-1mA or ±1mA 0-5mA or ±5mA 0-10mA or ±10mA 0-20mA or ±20mA 4-20mA					
Ro (kΩ)= 12V/Lo (mA)	0-10V or ±10V > 4kΩ 1-5V > 1kΩ 2-10V > 4kΩ					
Voltage standard output- - Load min. resistance	0-1V or ±1V > 1kΩ 0-5V or ±5V > 1kΩ 0-10V or ±10V > 4kΩ 1-5V > 1kΩ 2-10V > 4kΩ					
Max. output voltage under open circuit	17V					
Saturation limit	1.5Lo or 1.5Vo					

TRANSFER

Curves	E-F-K					
Class (Accuracy %)	1					
Linearity error	0.1%					

AUXILIARY SUPPLY

AC Voltage	100, 110, 220, 380, 440V ±20%					
Burden	3VA					
DC Voltage	12, 24, 48, 110V ±20%					
Burden	3W					

AMBIENT CONDITIONS

Temperature coefficient (0 to 60°C)	0.01%/°C					
--	----------	--	--	--	--	--

ORDERING DETAILS

ATA/ARA	ATAI/ARAI	ATAu/ARAU
Input Nominal Current	Input Nominal Current	Input Nominal Current
Output Nominal Current	Output Nominal Voltage/Current	Output Nominal Voltage/Current
	Auxiliary Supply	Auxiliary Supply

POWER AND ENERGY TRANSDUCERS

POWER TRANSDUCERS

Convert the power of a single or three-phase system into a proportional DC current or voltage signal. Connection diagrams, page 20

- For single-phase system

ATW – ARW – Active power

ATWr – ARWr – Reactive power

ATWV – ARWV – Active + Reactive power

- For three-phase balanced system

ATWI – ARWI – Active power

ATWIr – ARWIr – Reactive power

ATWVI – ARWVI – Active + Reactive power

- For three-phase unbalanced system

ATWII – ARWII – Active power

ATWIIr – ARWIIr – Reactive power

ATWVII – ARWVII – Active + Reactive power

- For three-phase unbalanced with neutral system

ATWIIIn – ARWIIIn – Active power

ATWIIInr – ARWIIInr – Reactive power

ENERGY TRANSDUCERS

Convert the energy of a single or three-phase system into a proportional number of impulses by an optoelectronic device, with potential free. Therefore the amplitude can be the user's choice.. Connection diagrams, page 21

- For single-phase system

ATE – ARE – Active power (One output for monodirectional energy and two outputs for bi-directional energy)

ATEr – AREr – Reactive power (One output for monodirectional energy and two outputs for bi-directional energy)

ATEV – AREV – Active + Reactive power (One output for monodirectional energy and two outputs for bi-directional energy, same for reactive)

- For three-phase balanced system

ATEI – AREI – Active power (same output as ATE)

ATEIr – AREIr – Reactive power (same output as ATE)

ATEVI – AREVI – Active + Reactive power (same output as ATEV)

- For three-phase unbalanced system

ATEII – AREII – Active power (same output as ATE)

ATEIIr – AREIIr – Reactive power (same output as ATE)

ATEVII – AREVII – Active + Reactive power (same output as ATEV)

- For three-phase unbalanced with neutral system

$ATEIIn - AREIIn$ – Active power (same output as ATE)

$ATEIInr - AREIInr$ – Reactive power (same output as ATE)

POWER + ENERGY TRANSDUCERS

Convert the power of a single or three-phase systems into a proportional DC current or voltage signal, and the energy into a proportional number of impulses. Connection diagrams, page 22

- For single-phase system

ATWE – ARWE – Active power (One output for monodirectional energy and two outputs for bi-directional energy)

ATWE_r – ARWE_r – Reactive power (One output for monodirectional energy and two outputs for bi-directional energy)

ATWEV – ARWEV – Active + Reactive power (One output for monodirectional energy and two outputs for bi-directional energy, same for reactive)

- For three-phase balanced system

ATWEI – ARWEI – Active power and energy

ATWEI_r – ARWEI_r – Reactive power and energy

ATWEVI – ARWEVI – Active + Reactive power and energy

- For three-phase unbalanced system

ATWEII – ARWEII – Active power and energy

ATWEII_r – ARWEII_r – Reactive power and energy

ATWEVII – ARWEVII – Active + Reactive power and energy

- For three-phase unbalanced with neutral system

ATWEIIn – ARWEIIn – Active power and energy

ATWEIIn_r – ARWEIIn_r – Reactive power and energy

TECHNICAL DATA	POWER TRANSDUCERS					
Type	ATW- ATWIIr	ARW- ARWIIr	ATWV ATWVI ATWVII	ARWV ARWVI ARWVII	ATWIIIn ATWIIInr	ARWIIIn ARWIIInr
Dimensions	Fig 2	12T	Fig 2	20T	Fig 2	12T

INPUT

Nominal value (Vn)	100,110,220,380,440V
Nominal value (In)	1 or 5A
Measuring range	0 to 1.2Pn or -1.2 to +1.2Pn
Frequency	50 to 60 Hz
Voltage burden per phase	1VA
Current burden per phase	0.4VA

OUTPUT

Current standard output Load max. resistance	0-1mA or ± 1 mA 0-5mA or ± 5 mA 0-10mA or ± 10 mA
Ro (k Ω)= 12V/Lo (mA)	0-20mA or ± 20 mA 4-20mA
Voltage standard output- - Load min. resistance	0-1V or ± 1 V > 1k Ω 0-5V or ± 5 V > 1k Ω 0-10V or ± 10 V > 4k Ω 1-5V > 1k Ω 2-10V > 4k Ω
Impulse output Frequency Time-on impulse Max. voltage Max. output current	-----
Max. output voltage under open circuit	17V
Saturation limit	2Lo or 2Vo

TRANSFER

Curves	A-B-C-D-E-F-I-K	
Class (Accuracy %)	0.5	
Linearity error	0.1%	0.2%

AUXILIARY SUPPLY

AC Voltage	100, 110, 220, 380, 440V $\pm 20\%$
Burden	4VA
DC Voltage	12, 24, 48, 110V $\pm 20\%$
Burden	4W

AMBIENT CONDITIONS

Temperature coefficient (0 to 60°C)	0.01%/°C	0.02%/°C
--	----------	----------

ORDERING DETAILS

Voltage	Current	Power transformer
Frequency	Auxiliary supply	Output nominal curr. or volt.

TECHNICAL DATA	ENERGY TRANSDUCERS					
Type	ATE- ATEIIr	ARE- AREIIr	ATEV ATEVI ATEVII	AREV AREVI AREVII	ATEIIIn ATEIIInr	AREIIIn AREIIInr
Dimensions	Fig 2	12T	Fig 2	20T	Fig 2	12T

INPUT

Nominal value (Vn)	100,110,220,380,440V
Nominal value (In)	1 or 5A
Measuring range	0 to 1.2Pn or -1.2 to +1.2Pn
Frequency	50 to 60 Hz
Voltage burden per phase	1VA
Current burden per phase	0.4VA

OUTPUT

Current standard output Load max. resistance	-----
Ro (kΩ)= 12V/Lo (mA)	
Voltage standard output- - Load min. resistance	-----
Impulse output Frequency	200 to 25,000 imp/h
Time-on impulse	100ms
Max. voltage	50V
Max. output current	100mA
Max. output voltage under open circuit	-
Saturation limit	-

TRANSFER

Curves	A-B-E
Class (Accuracy %)	0.5
Linearity error	

AUXILIARY SUPPLY

AC Voltage	100, 110, 220, 380, 440V ±20%
Burden	4VA
DC Voltage	12, 24, 48, 110V ±20%
Burden	4W

AMBIENT CONDITIONS

Temperature coefficient (0 to 60°C)	0.01%/°C	0.02%/°C
--	----------	----------

ORDERING DETAILS

Voltage	Current	Energy transformer
Frequency	Auxiliary supply	Number on imp/h.

TECHNICAL DATA	POWER + ENERGY TRANSDUCERS					
Type	ATWE- ATWEIIr	ARWE- ARWEIIr	ATWEV ATWEVI ATWEVII	ARWEV ARWEVI ARWEVII	ATWEIIIn ATWEIIInr	ARWEIIIn ARWEIIIn r
Dimensions	Fig 2	12T	Fig 2	20T	Fig 2	12T

INPUT

Nominal value (Vn)	100,110,220,380,440V
Nominal value (In)	1 or 5A
Measuring range	0 to 1.2Pn or -1.2 to +1.2Pn
Frequency	50 to 60 Hz
Voltage burden per phase	1VA
Current burden per phase	0.4VA

OUTPUT

Current standard output Load max. resistance	0-1mA or ± 1 mA 0-5mA or ± 5 mA 0-10mA or ± 10 mA
Ro (k Ω)= 12V/Lo (mA)	0-20mA or ± 20 mA 4-20mA
Voltage standard output- - Load min. resistance	0-1V or ± 1 V > 1k Ω 0-5V or ± 5 V > 1k Ω 0-10V or ± 10 V > 4k Ω 1-5V > 1k Ω 2-10V > 4k Ω
Impulse output Frequency Time-on impulse Max. voltage Max. output current	200 to 25,000 imp/h 100ms 50V 100mA
Max. output voltage under open circuit	17V
Saturation limit	2Lo or 2Vo

TRANSFER

Curves	Power A-B-C-D-E-F-I-K / Energy A-B-E	
Class (Accuracy %)	0.5	
Linearity error	0.1%	0.2%

AUXILIARY SUPPLY

AC Voltage	100, 110, 220, 380, 440V $\pm 20\%$
Burden	4VA
DC Voltage	12, 24, 48, 110V $\pm 20\%$
Burden	4W

AMBIENT CONDITIONS

Temperature coefficient (0 to 60°C)	0.01%/°C	0.02%/°C
--	----------	----------

ORDERING DETAILS

Voltage	Current	Power transformer
Frequency	Auxiliary supply	Output nominal curr. or volt.

ARW-ARWr
ATW-ATWr

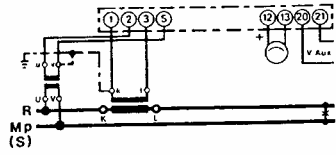

ARWV
ATWV

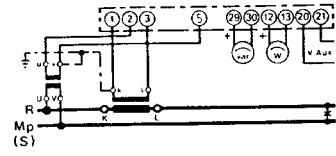

ARWI
ATWI

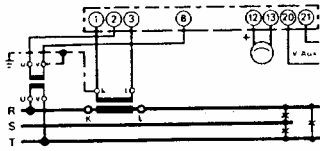

ARWVI
ATWVI

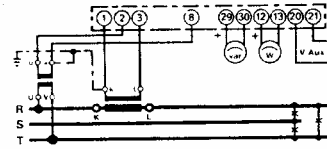

ARWIr
ATWIr

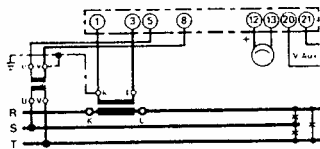

ARWVII
ATWVII

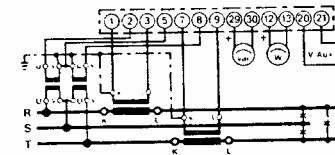

ARWII-ARWIIr
ATWII-ATWIIr

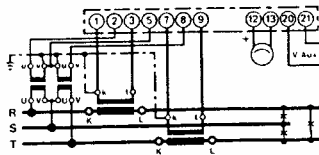

ARWIIIn-ARWIIInr
ATWIIIn-ATWIIInr

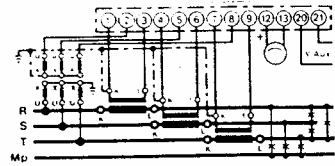

ARE-AREr
ATE-ATER

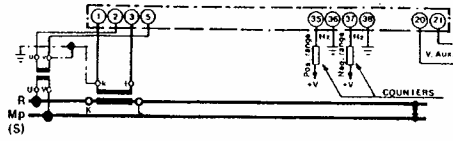

AREV-ATEV

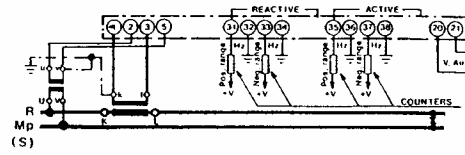

AREI-ATEI

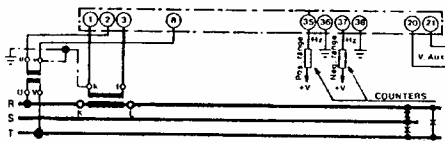

AREVI-ATEVI

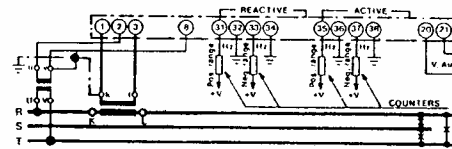

AREIr-ATEIr

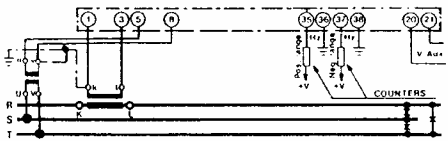

AREVII-ATEVII

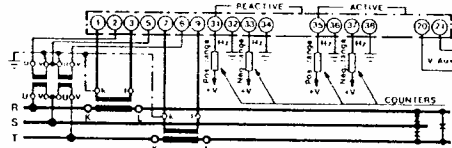

AREII-ATEII
AREIIr-ATEIIr

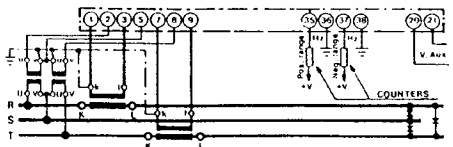

AREIIIn-ATEIIIn
AREIIInr-ATEIIInr

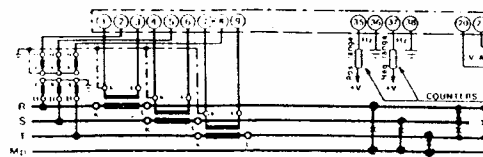

ARWE-ATWE
ARWEr-ATWEr

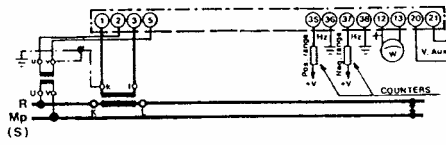

ARWEV-ATWEV

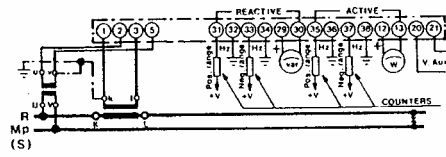

ARWEI-ATWEI

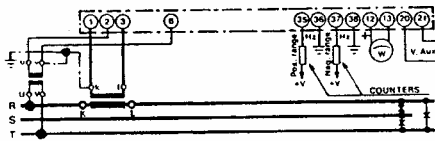

ARWEVI-ATWEVI

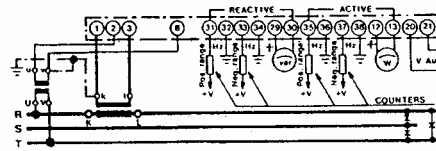

ARWEIr-ATWEIr

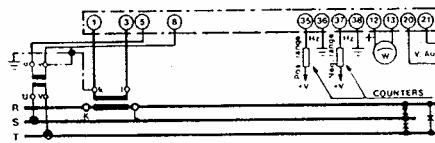

ARWEVII-ATWEVII

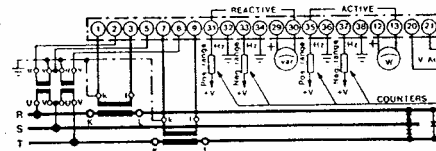

ARWEII-ATWEII
ARWEIIr-ATWEIIr

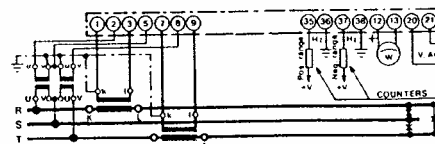

ARWEIIIn-ATWEIIIn
ARWEIIInr-ATWEIIInr

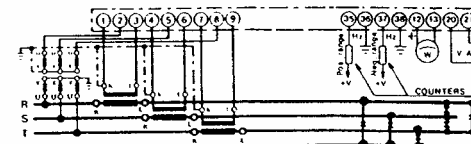

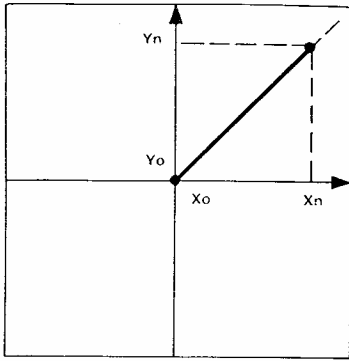

FIG. A
Input Output
Xo Yo
Xn Yn

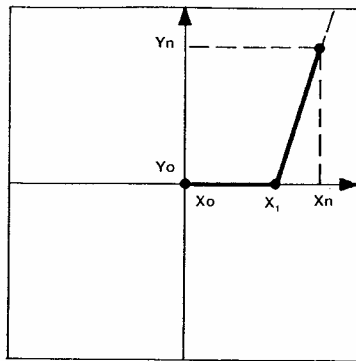

FIG. B
Input Output
Xo Yo
X1 Yo
Xn Yn

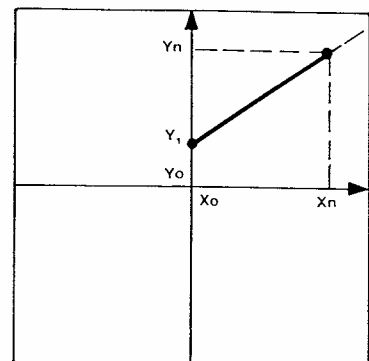

FIG. C
Input Output
Xo Y1 = 0.2 Yn
Xn Yn

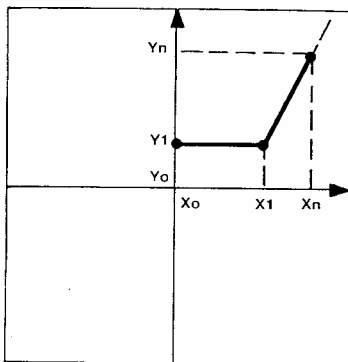

FIG. D
Input Output
Xo Y1 = 0,2 Yn
X1 Y1 = 0,2 Yn
Xn Yn

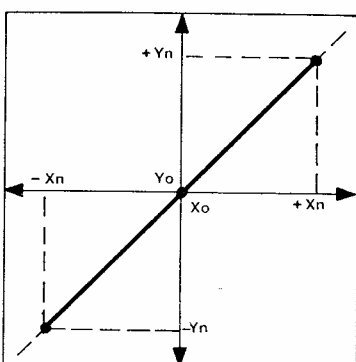

FIG. E
Input Output
- Xn - Yn
Xo Yo
+ Xn + Yn

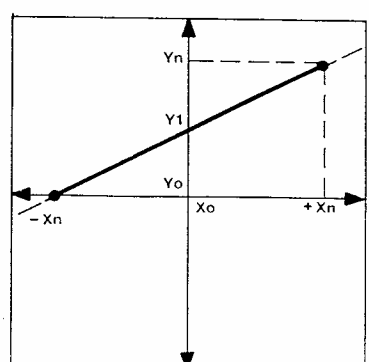

FIG. F
Input Output
- Xn Yo
Xo Y1
+ Xn Yn

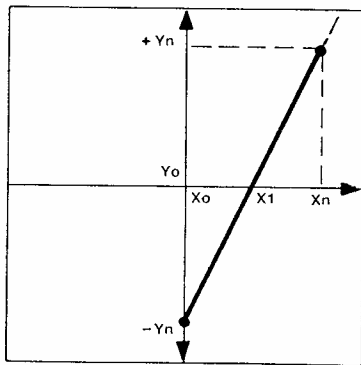

FIG. I
Input Output
Xo - Yn
X1 Yo
Xn + Yn

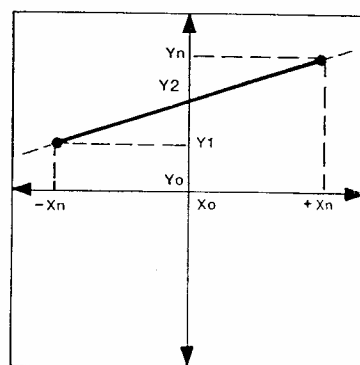

FIG. K
Input Output
- Xn Y1
Xo Y2
+ Xn Yn