

## Notes

# **PREFACE**

**PM390 Operating Guide  
Revision 1.10  
December 1999**

This manual represents your meter as manufactured at the time of publication. It assumes standard software. Special versions of software may be fitted, in which case you will be provided with additional details.

Every effort has been made to ensure that the information in this manual is complete and accurate. We revised this manual but cannot be held responsible for errors or omissions.

The apparatus has been designed and tested in accordance with IEC 1010-1, 'Safety Requirements for Electrical Equipment for Measurement, Control and Laboratory Use'. This operating guide contains information and warnings which must be followed by the user to ensure safe operation and to maintain the apparatus in a safe condition.

We reserve the right to make changes and improvements to the product without obligation to incorporate these changes and improvements into units previously shipped.

General Editor : Ian Sykes BSc (hons).

Copyright © 1999 : Northern Design (Electronics) Ltd,  
228 Bolton Road, Bradford. West Yorkshire. UK.

# Contents

---

<b>1. SAFETY .....</b>	<b>4</b>
1.1 WARNING SYMBOLS.....	4
1.2 MAINTENANCE .....	4
<b>2. METER OPERATION.....</b>	<b>5</b>
2.1 MEASUREMENTS.....	5
2.2 DISPLAY PAGES.....	6
2.3 DISPLAY MENUS .....	11
2.4 DYNAMIC DISPLAYS .....	12
2.5 REFERENCE LED (REF).....	12
2.6 NON-VOLATILE MEMORY.....	13
2.7 REAL TIME CLOCK .....	13
2.8 ROLLING AVERAGE DEMAND .....	13
2.9 AUTO ROTATION.....	14
2.10 BALANCED VOLTAGE MODE.....	14
<b>3. INSTALLATION .....</b>	<b>15</b>
3.1 PANEL MOUNTING.....	15
3.2 CONNECTION.....	17
3.3 SCHEMATICS .....	20
<b>4. ISOLATED RELAY OUTPUTS (OPTIONAL).....</b>	<b>26</b>
4.1 GENERAL DESCRIPTION .....	26
4.2 PULSE OUTPUTS.....	26
4.3 ALARM OUTPUTS .....	26
4.4 CONNECTING THE RELAYS.....	27
<b>5. ANALOGUE OUTPUTS (OPTIONAL).....</b>	<b>28</b>
5.1 GENERAL DESCRIPTION .....	28
5.2 CONNECTING THE ANALOGUE OUTPUTS .....	29

---

<b>6. PROGRAMMING</b> .....	<b>31</b>
6.1 DESCRIPTION.....	31
6.2 ENTERING PROGRAMMING MODE.....	32
6.3 SELECTING PROGRAMMING OPTIONS.....	32
6.4 EXITING PROGRAMMING MODE.....	32
6.5 DISABLING PROGRAMMING.....	33
6.6 SETTING THE CT. PRIMARY CURRENT.....	34
6.7 SETTING THE PT. RATIO.....	35
6.8 RESET ENERGY REGISTERS.....	36
6.9 RELAY OUTPUT SET-UP.....	37
6.10 TOGGLE CT AUTO ROTATION.....	44
6.11 TOGGLE BALANCED VOLTAGE MODE.....	45
6.12 ANALOGUE OUTPUT SET-UP.....	47
6.13 SETTING THE METER COMMUNICATION CHANNEL.....	52
6.14 SETTING THE REAL TIME CLOCK (RTC).....	52
6.15 SETTING THE MD AND ROLLING AVERAGE INTEGRATION PERIOD.....	55
6.16 RESET MAXIMUM DEMAND AND ROLLING AVERAGE REGISTERS.....	57
<b>7. SERIAL COMMUNICATION</b> .....	<b>59</b>
7.1 INTRODUCTION.....	59
7.2 COMMUNICATION ADDRESS.....	59
7.3 DATA FORMAT.....	59
7.4 RS232.....	59
7.5 RS485.....	60
7.6 RS422.....	62
7.7 COMMUNICATION PROTOCOL.....	63
7.8 DATA TABLES.....	67
7.9 RTU COMMANDS.....	79
7.10 EXCEPTION RESPONSES.....	84
<b>8. SPECIFICATION</b> .....	<b>85</b>

## 1. Safety

### 1.1 Warning Symbols

This manual provides details of safe installation and operation of the meter. Safety may be impaired if the instructions are not followed. Labels on individual meters give details of equipment ratings for safe operation. Take time to examine all labels on the meter and to read this manual before commencing installation.

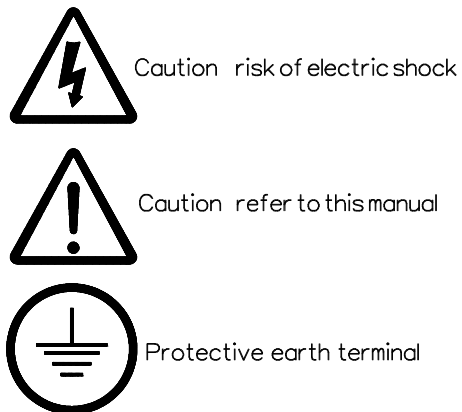

**Figure 1.1 Safety Symbols**

**WARNING**

The meter contains no user serviceable parts. Installation and commissioning should be carried out by qualified personnel

### 1.2 Maintenance

The equipment should be maintained in good working order. Damage to the product should be repaired by the manufacturer or authorised agent. The front panel of the PM390 may be cleaned by wiping lightly with a soft cloth. No solvents or cleaning agents should be used. All input and supplies must be isolated before cleaning any other part of the equipment.

## 2. Meter Operation

### 2.1 Measurements

The PM390 makes use of a high speed micro-processor and an Analogue to Digital converter to monitor input signals from three independent phases. Each phase voltage, current and power (kW) are measured directly. Other parameters are derived from these in software.

The measurement process is continuous with all six signals scanned simultaneously at high speed. Unlike many other sampling systems, which sample one phase after another, this ensures that all input cycles are detected. Distorted input waveforms, with harmonics to the 20th are therefore detected accurately.

Derived parameters are calculated and displayed approximately once a second, scaled by user programmed constants for current and voltage transformers. A floating point processor provides true r.m.s. readings over a wide range of inputs. Instantaneous power parameters are integrated over long time periods providing a number of energy registers.

System frequency is detected by digital processing of the phase 1 voltage signal.

# Operation

---

## 2.2 Display Pages

A list of pages available for display throughout the range of PM390 meters is shown below. Pages displaying Maximum Demand are optional and only available if supplied with an individual meter.

Note : Positive instantaneous values are displayed without a preceding sign.

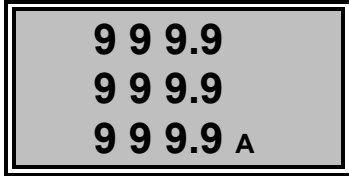

999.9  
999.9  
999.9 A

### Per Phase Amps.

Individual rms. phase currents input via CT1 (top), CT2 (mid) and CT3 (btm). Values shown indicate currents on the primary side of any external current transformers.

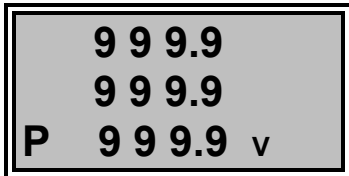

999.9  
999.9  
P 999.9 v

### Per Phase Volts (Line-Neutral).

Individual rms. phase voltages input at L1 (top), L2 (mid) and L3 (btm). Values shown indicate those on the primary side of any external voltage transformers.

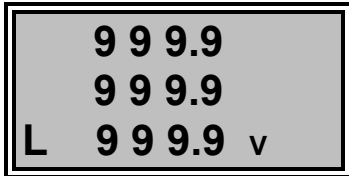

999.9  
999.9  
L 999.9 v

### Per Phase Volts (Line-Line).

Individual rms line voltages input at L1-L2 (top), L2-L3 (mid) and L3-L1 (btm). Values shown indicate those on the primary side of any external voltage transformers.

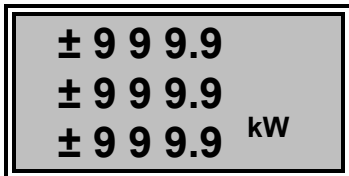

±999.9  
±999.9  
±999.9 kW

### Per Phase Real Power (Watts)

Individual rms watts measured from current and voltage waveforms on phase 1 (top), phase 2 (mid) and phase 3 (btm). A negative value indicates export power

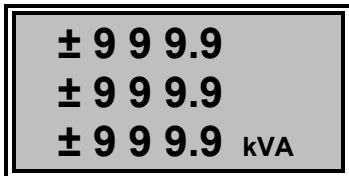

±999.9  
±999.9  
±999.9 kVA

### Per Phase Apparent Power (VA)

Individual Volt Amperes derived from rms currents and voltages measured on phase 1 (top), phase 2 (mid) and phase 3 (btm). A negative value indicates export power.



± 9 9 9.9  
± 9 9 9.9  
± 9 9 9.9 kVAr

**Per Phase Reactive Power (var)**  
Individual var values derived from VA and Watts measured on phase 1 (top), phase 2 (mid) and phase 3 (btm). A negative value indicates a capacitive load.

± 1.0 0 0  
± 1.0 0 0 PF  
± 1.0 0 0

**Per Phase Power Factor.**  
Individual phase PF values derived from VA and Watts measured on phase 1 (top), phase 2 (mid) and phase 3 (btm). A negative value indicates a capacitive load.

9 9 9.9 Peak  
9 9 9.9  
P 9 9 9.9 v

**Per Phase Peak Volts.**  
The maximum rms phase voltage recorded on each phase since **RESET** was last pressed while on this page. These values are derived from the rms values defined above.

9 9 9.9 Peak  
9 9 9.9  
9 9 9.9 A

**Per Phase Peak Amps.**  
The maximum rms current recorded on each phase since **RESET** was last pressed while on this page. These values are derived from the rms values defined above.

## Operation

---

**3 - P h**  
± 999.9 kW  
± 999.9 kVA

### Total system (3-Phase) Watts and VA

The middle line shows the sum of all 3 phase watts. The bottom line shows the sum of all 3 phase volt-amperes.

Negative values in both cases indicate export power.

**3 - P h**  
± 999.9 kW  
± 999.9 kVA<sub>r</sub>

### Total system (3-Phase) Watts and VAR

The middle line shows the sum of all 3 phase watts. The bottom line shows the 3-phase Reactive volt-amperes. A negative value for kvar indicates a capacitive load.

**3 - P h**  
± 1.000<sup>PF</sup>  
50.00 hz

### Total (3-Phase) PF and Frequency

The middle line shows the system power factor derived from system kW / kVA.

The bottom line shows the fundamental frequency of the phase 1 voltage waveform.

**A V E**  
999.9 v  
999.9 A

### Average Voltage and Current.

The middle line shows the mathematical average of the 3 phase voltages derived from displayed values defined above. The bottom line shows that of the 3 phase currents.

**r O L L<sup>Peak</sup>**  
± 999.9  
P ± 999.9 kW

### 3-Ph Rolling Ave kW & Peak Demand

The middle line shows the average of a series of kW readings taken over the MD period. The bottom line shows the maximum value of this average reached since last reset.

**r O L L<sup>Peak</sup>**  
± 999.9  
P ± 999.9 kVA

### 3-Ph Rolling Ave kVA & Peak Demand

The middle line shows the average of a series of kVA readings taken over the MD period. The bottom line shows the maximum value of this average reached since last reset.

3 - P h  
9 9 9 9 9.9 KWh

**Imported 3-Phase Real Energy (kWh).**  
Total three phase real energy register derived from system watts defined above. This register accumulates while system watts are positive.

3 - P h  
9 9 9 9 9.9 KVA h

**Imported 3-Phase Apparent Energy (kVAh)**  
Total three phase apparent energy register derived from system volt-amperes defined above. This register accumulates while system VA is positive.

3 - P h  
I n d  
9 9 9 9 9.9 KVArh

**Imported 3-Phase Inductive kVArh**  
Inductive three phase reactive energy register derived from system reactive Volt-Amperes defined above. This register accumulates while system var is positive.

3 - P h  
C A P  
9 9 9 9 9.9 KVArh

**Imported 3-Phase Capacitive kVArh**  
Capacitive three phase reactive energy register derived from system reactive Volt-Amperes defined above. This register accumulates while system var is negative.

3 - P h  
t o t  
9 9 9 9 9.9 KVArh

**Imported 3-Phase Total kVArh**  
Total three phase reactive energy register derived as the sum of the absolute values of inductive and capacitive registers defined above. This register accumulates whenever system var is not zero.

## Operation

---

9 9 9.9 Peak  
9 9 9.9 MD  
23:59:59 kW

### 3-Phase kW Max Demand (Optional)

The top line shows the highest period kW demand since it was last reset. The middle line shows the current period accumulating value and the bottom line the time of day.

9 9 9.9 Peak  
9 9 9.9 MD  
23:59:59 KVA

### 3-Phase kVA Max Demand (Optional)

The top line shows the highest period kVA demand since it was last reset. The middle line shows the current period accumulating value and the bottom line the time of day.

3 - P h  
n E G  
9 9 9 9 9.9 kWh

### Exported 3-Phase Real Energy

Total three phase exported real energy register derived from system watts defined above. This register accumulates while system watts are negative. This parameter is not displayed if CT Auto Rotation is enabled.

3 - P h  
n E G  
9 9 9 9 9.9 KVA h

### Exported 3-Phase Apparent Energy

Total three phase exported apparent energy register derived from system Volt-Amperes defined above. This register accumulates while system VA is negative. This parameter is not displayed if CT Auto Rotation is enabled.

### 2.3 Display Menus

The display pages shown above are organised into three menus for convenience. Table 2-1 shows how the pages are organised.

The **1ö** key selects the per phase menu, the **3ö** key selects the system (3-Phase) menu and the **ENERGY** key (**1ö** and **3ö** keys together) selects the Energy menu as required. The **NEXT** and **PREV** keys are used to step between each page on the selected menu.

1ö (Per Phase) NEXT ↓ PREV ↑	3ö (3-Phase) NEXT ↓ PREV ↑	ENERGY NEXT ↓ PREV ↑
$I_1, I_2, I_3$	3-Ph kW and kVA	kWh
$V_{1n}, V_{2n}, V_{3n}$	3-Ph kW and kvar	kVAh
$V_{12}, V_{23}, V_{31}$	3-Ph PF and Freq	Inductive kvarh
$kW_1, kW_2, kW_3$	Ave Phase V and I	Capacitive kvarh
$kVA_1, kVA_2, kVA_3$	Rolling Ave kW	Total Sum kvarh
$PF_1, PF_2, PF_3$	Rolling Ave kVA	kW MD. (Optional)
$kvar_1, kvar_2, kvar_3$		kVA MD. (Optional)
Peak $V_{1n}, V_{2n}, V_{3n}$		Export kWh <sup>1</sup>
Peak $I_1, I_2, I_3$		Export kVAh <sup>1</sup>

Table 2-1 Organisation Of Display Menus

<sup>1</sup> Export energy registers are suppressed if CT Auto Rotation is enabled. In this mode export power is automatically converted to import by the meter.

## Operation

---

### 2.4 Dynamic Displays

The display of instantaneous parameters is controlled to provide maximum resolution under all loading conditions. This is termed 'Dynamic Display'. Dynamic Displaying involves **automatic** adjustment of decimal point and legend prefix (e.g. W, kW, MW, etc.) ensuring 4 digits of resolution on the display at all times. On pages in the per phase menu all three lines are shown with a single legend to ease reading. The largest phase value measured dictates the scaling for the entire page.

Table 2-2 shows an example of Dynamic Displaying for instantaneous real power (Watts) over a wide input range.

<i>Measured Load</i>	<i>Displayed Value</i>
<b>10 Watts</b>	<b>1 0.0 0 W</b>
<b>100 Watts</b>	<b>1 0 0.0 W</b>
<b>1,000 Watts</b>	<b>1.0 0 0 kW</b>
<b>10,000 Watts</b>	<b>1 0.0 0 kW</b>
<b>100,000 Watts</b>	<b>1 0 0.0 kW</b>
<b>1,000,000 Watts</b>	<b>1 0 0 0 kW</b>
<b>10,000,000 Watts</b>	<b>1 0.0 0 MW</b>

Table 2-2 Dynamic Display Of Power

### 2.5 Reference LED (REF).

A light emitting diode (LED) is provided on the front panel of the meter which pulses at a speed proportional to instantaneous kW. This may be thought of as a replacement for the rotating disc on a traditional Ferraris (Electro-Mechanical) electricity meter.

Each LED pulse represents a single increment in the kWh register and lasts for a period of approximately 100mS. The LED flashes regardless of the page currently being displayed.

## **2.6 Non-Volatile Memory**

Standard meters use non-volatile memory to store system parameters in the event of auxiliary mains power failure or brown-out.

The memory devices are inherently secure and do not require a battery or other circuitry to maintain a backup supply. This ensures long term data retention (25 years) with no need for servicing or battery replacement. The non-volatile memory stores programmed settings (e.g. CT primary), all energy registers and meter calibration data.

## **2.7 Real Time Clock**

Meters displaying maximum demand and/or real time have a real time clock circuit fitted internally. This circuit also provides non-volatile memory replacing that described in section 2.6.

The real time clock circuit requires a backup supply to maintain timing in the event of auxiliary mains failure. This supply also provides non-volatile memory data retention. The backup supply is provided by an internal lithium battery which will last for a period in excess of 15 years under normal operation. The battery should be replaced only by an authorised dealer.

## **2.8 Rolling Average Demand**

This parameter is sometimes used as an alternative to true (real time linked) maximum demand. It provides an average reading of power over a given time period. A “rolling” time period is used which continuously updates, starting a full time period prior to the last display update. In the PM390 the time period is the same as that programmed for the true maximum demand.

The PM390 display shows two readings for each power parameter (kW and KVA). The **Rolling Average** shows the average power measured over the most recent time period (eg 30 min). The **Peak Rolling Average** shows the largest value recorded since the last MD reset.

The MD time period may be set as 5, 10, 15, 20 or 30 minutes. For information on setting the MD time period refer to 6.15. For information on resetting the rolling averages refer to section 6.16.

### **2.8.1 How It Is Calculated In The PM390**

Each MD time period is split into **30** shorter periods (unless specified otherwise). The average of all the power readings taken during each short period is calculated. The latest average is stored in place of the oldest thus providing an array of the 30 most recent averages. The average of the 30 readings is displayed as **Rolling Average**. The largest rolling average recorded since the previous MD reset is displayed as the **Peak Rolling Average**.

### 2.9 Auto Rotation

The most common wiring error on three phase metering is incorrect rotation of current transformers on the primary conductor. It is not always apparent, from physical wiring layout, the direction of current flow in an installed system. If CTs are installed in anti-phase to the supply to load current direction, negative measurements of kW and kVA will result (i.e. export) and the associated import energy registers will not accumulate.

Auto Rotation provides a means of correction for this type of wiring error. If enabled (refer to section 6.10) Auto Rotation forces kW and kVA readings to a positive value before measurement scaling and display.

#### How to use Auto Rotation

- ◆ Standard meters have Auto Rotation ON as a factory default setting.
- ◆ Always attempt to install CTs in the correct orientation, maintaining agreement with schematic diagrams and saving future confusion if adding other equipment.
- ◆ If the meter is required to measure only **imported** power/energy values, **ENABLE** Auto Rotation.
- ◆ If **exported** power/energy measurements are required, **DISABLE** Auto Rotation.

### 2.10 Balanced Voltage Mode

Balanced voltage mode provides a means of measuring three phase loads using three currents but only a single phase 1 voltage. The software measures all phase 1 parameters, r.m.s currents on phase 2 and 3 and makes the following assumptions for the remaining measurements

#### Assumptions made by the meter :

- ◆ **Phase 1 PF = Phase 2 PF = Phase 3 PF**
- ◆ **Phase 1 Volts = Phase 2 Volts = Phase 3 Volts**
- ◆ **Phase 2 kW = Phase 1 PF \* Phase 1 Volts \* Phase 2 Amps**
- ◆ **Phase 3 kW = Phase 1 PF \* Phase 1 Volts \* Phase 3 Amps**

Balanced voltage mode is enabled in programming mode as described in section 6.11. It is **recommended** that balanced voltage mode, albeit convenient, is only used where it is impractical to connect all three voltages, e.g. when the meter is used in portable applications, taking voltage measurement from the auxiliary mains supply. The assumptions made have a significant effect on accuracy in most cases.

### 3. Installation

#### 3.1 Panel Mounting

The PM390 is designed to be mounted in a panel. The meter enclosure is DIN standard 96mm x 96mm allowing use of standard punches. Panels should be of thickness 1mm to 4mm with a square cut out of 92mm (+0.8, -0.0). A minimum depth of 163mm should be allowed behind the panel for the meter and its wiring.

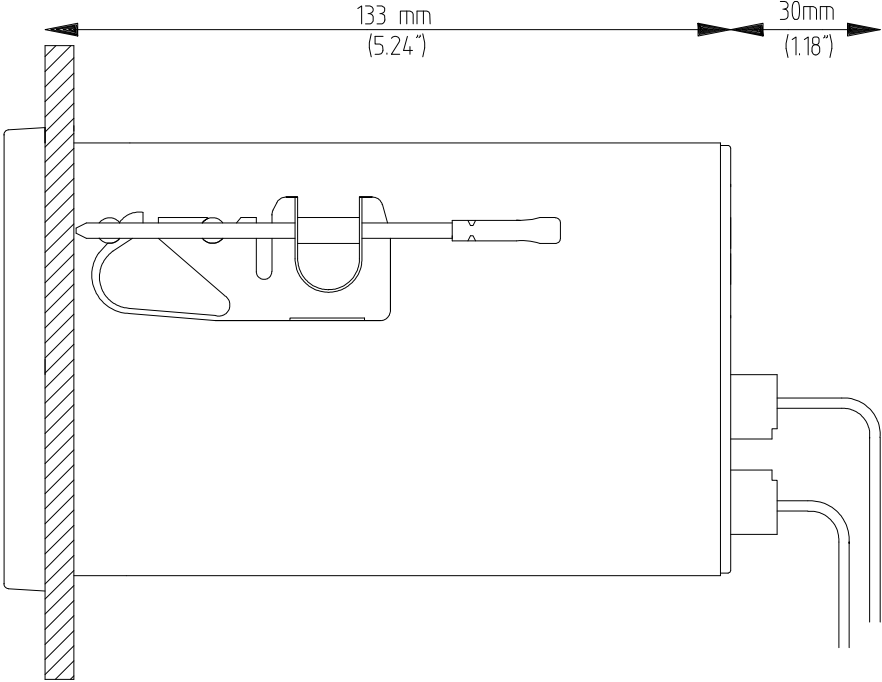
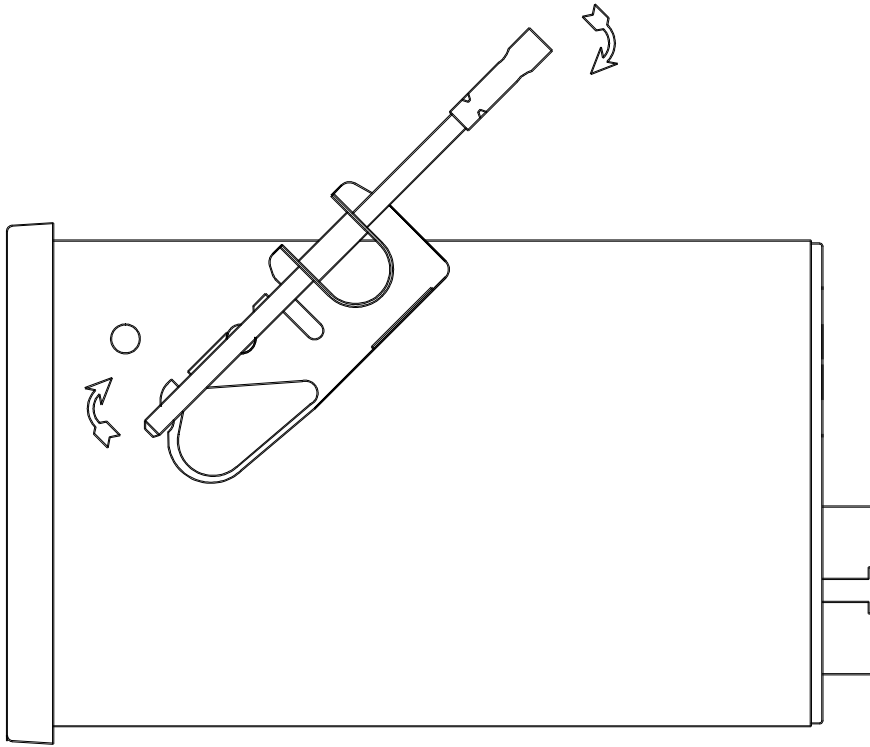

Figure 3.1 Meter Depth



**Figure 3.2 Fitting The Screw Mounting Clip**

Slide the instrument into the cut out from the front of the panel. Fit the screw mounting clip as shown on either side of the case. Use a flat screwdriver to adjust the screw to secure the meter in the panel. ***DO NOT OVERTIGHTEN.***

3.2 Connection

3.2.1 Terminations

All terminations are made at the rear panel of the PM390 after securing the meter in the panel. The layout of the panel is shown in Figure 3.3.

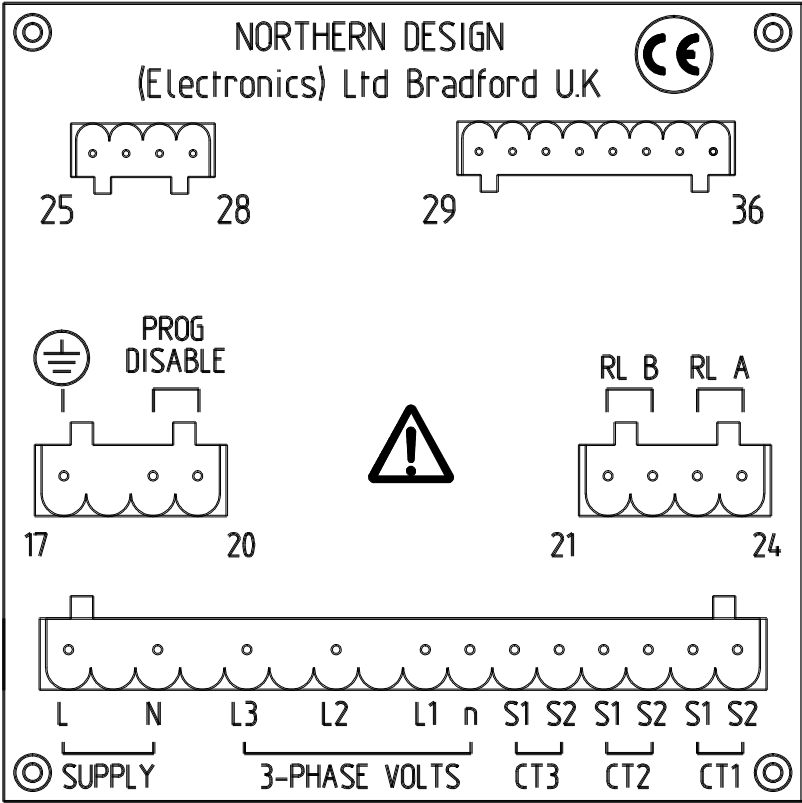

Figure 3.3 PM390 Rear Panel Layout

3.2.2 Protective Earth 

A protective earth terminal is provided. This must be connected to a system safety earth before making any other connection.

## Installation

---

### 3.2.3 The Current Circuit (CT1, CT2 and CT3)

The cable used for the current circuit should be insulated to a minimum of 600V AC r.m.s. The internal conductors must be rated at 6 Amps or greater. In order to achieve optimum accuracy the cable conductors should have a cross sectional area of  $2.5\text{mm}^2$ . This is the maximum size specified for the instrument's connectors.

The current circuit is designed for connection to the secondaries of industry standard current transformers. These are nominally rated 5 Amps but the meter may optionally be manufactured for use with 1 Amp secondaries. CTs should conform to Class 1 per BS 7626 (IEC 185) or equivalent. These standards provide performance/accuracy criteria over the full operating range of the meter. Permanent installation types such as toroidal or split-core are recommended.

#### **WARNING**

**NEVER** leave the secondary circuit of a CT open-circuit while a primary current flows. In this condition hazardous voltages may be present at the secondary terminals. Each CT secondary should be short-circuit when not connected to the meter.

### 3.2.4 The 3-Phase Voltage Circuit (n, L1, L2 and L3)

The cable used to connect the three phase voltage sense circuit should be insulated to a minimum of 600V AC r.m.s. The internal conductors should have a current rating of at least 250mA. The maximum cross sectional area for the conductor is  $2.5\text{mm}^2$ .

Connection to voltages greater than the maximum rating of the meter may be made using instrument grade (Class 1) potential transformers (PTs). Measurements may be scaled to take account of the transformation ratio as described in section 6.7.

#### 3.2.4.1 Protection Fuses

When installing any type of fixed metering it is good practice to provide fused protection. Fuses may be shared with other equipment but should be mounted as close as possible to it.

The three phase voltage inputs of the PM390 require no more than 1mA per channel under no-fault conditions. Fuses should be rated to suit the total input requirements for all protected equipment. The maximum rupture current rating for protection fuses in a system containing only PM390 meters is 160mA.

### 3.2.5 Auxiliary Mains Supply (N and L)

Solid state meters require a mains supply to power their measurement circuit. In some products this is connected internally to the measurement inputs restricting the input range (usually to  $V_{nom} \pm 10\%$ ).

The PM390 provides an isolated auxiliary mains supply separate from the measurement inputs. The system designer may choose to externally connect this input in parallel with the measurement inputs or to a separate single phase source.

As a general rule supplying auxiliary power from the measurement inputs is acceptable. Separate connection is made for example if :

- ◆ Measurement voltages vary over a wide range
- ◆ Power availability is restricted (e.g. on PT secondaries)
- ◆ A backup supply is required to maintain meter display.

**NOTE :** The meter maintains set-up data and energy readings in non-volatile memory for up to 25 years in the event of auxiliary mains failure.

As standard the auxiliary mains supply is rated at 230V  $\pm 15\%$ , 45-65Hz, 6W(max). Optional voltages are available (e.g. 115V  $\pm 15\%$ ) on request. The auxiliary mains supply is internally fused at 100mA (Type T).

**WARNING**

**DO NOT EXCEED THE RATED VOLTAGE** of the meter as this may impair safety or cause permanent damage to the product. The maximum rating for the auxiliary input is indicated on the meter enclosure.

# Installation

## 3.3 Schematics

### 3.3.1 3-Phase 3-Wire Load (2 CTs)

This connection is the standard method if a 3-Phase neutral is not available (Delta). Only two CTs are required as the third current is derived by the connection. This method is suitable for balanced and unbalanced loads.

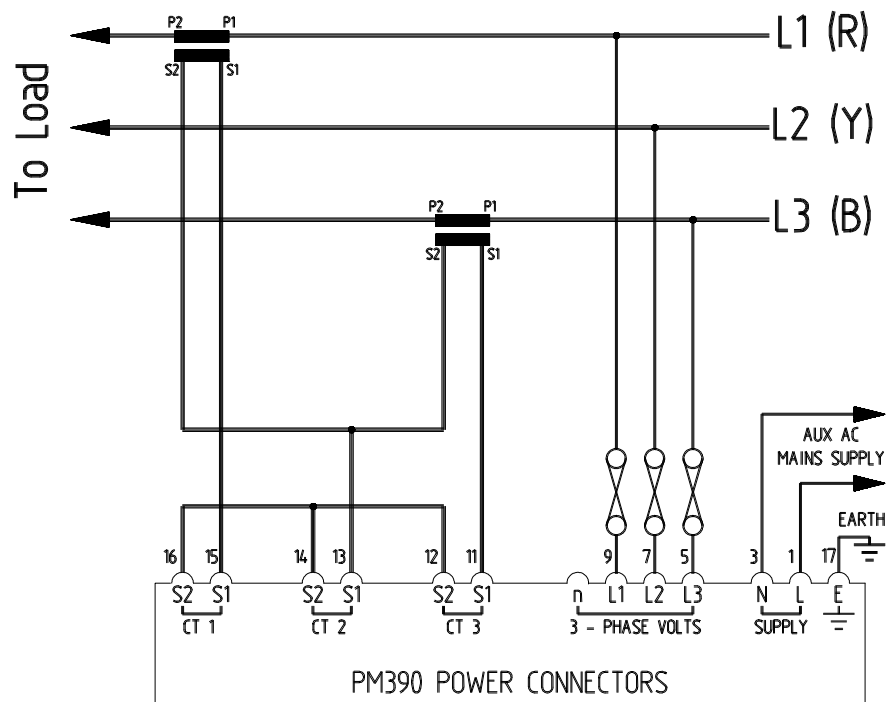

Figure 3.4 Schematic 3-Phase 3-Wire (2 CTs)

### 3.3.2 3-Phase 3-Wire Load (3 CTs)

This connection is a variation on 3.3.1 using a CT to measure the third current directly. This may improve accuracy in the presence of earth leakage currents. This method is suitable for balanced and unbalanced loads.

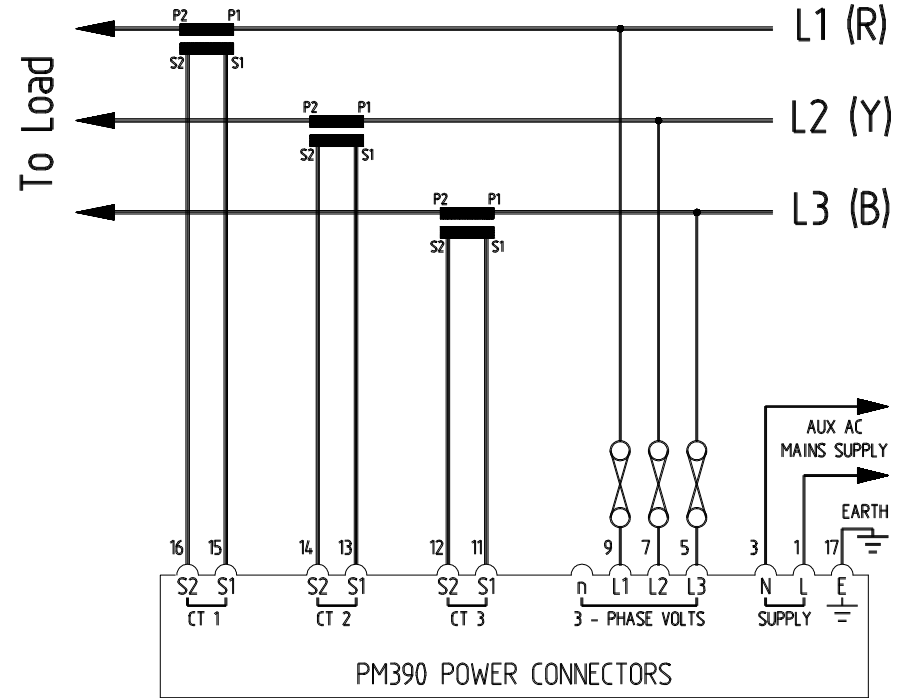

Figure 3.5 Schematic 3-Phase 3-Wire (3 CTs)

# Installation

## 3.3.3 3-Phase 4-Wire Load

This connection should be used if the load has a neutral wire available (Star). This method must be used if a neutral current is present. Three current transformers are essential for correct operation. This method is suitable for balanced and unbalanced loads.

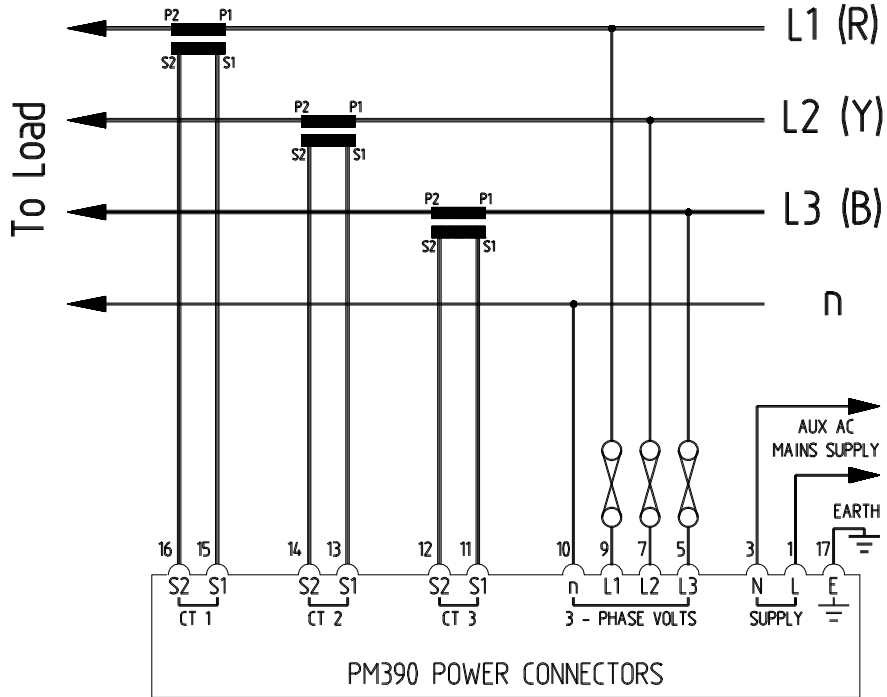

Figure 3.6 Schematic 3-Phase 4-Wire

### 3.3.4 Single Phase Load

It is possible to detect single phase power by utilising only one input channel.

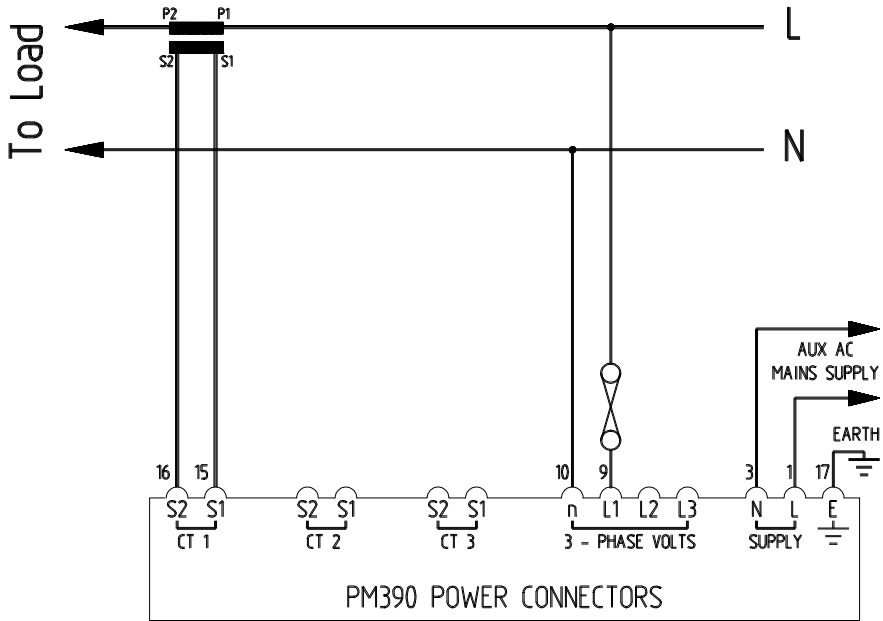

Figure 3.7 Schematic Single Phase

# Installation

## 3.3.5 3-Phase 3-Wire Using Potential Transformers

Potential transformers may be connected to reduce high system voltages to a level suitable for measurement. An example of the use of PTs is shown here.

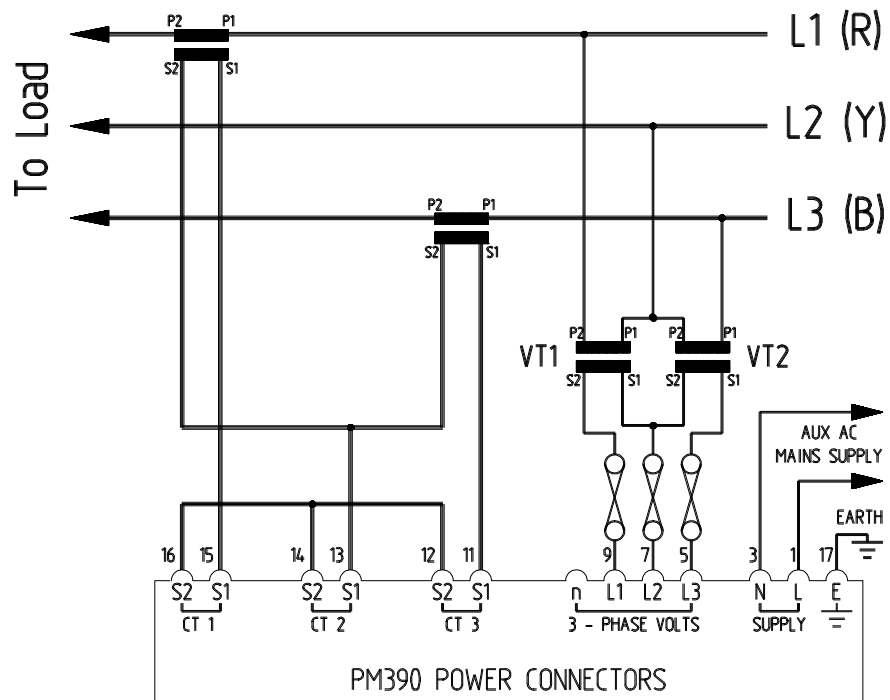

Figure 3.8 Schematic Example Use Of PTs

### 3.3.6 Adding Multiple Loads

It is possible to connect a meter to add multiple loads by making use of summation current transformers. Addition of two independent 3-Phase 4-Wire loads is shown below using three (5A+5A):5A summation transformers.

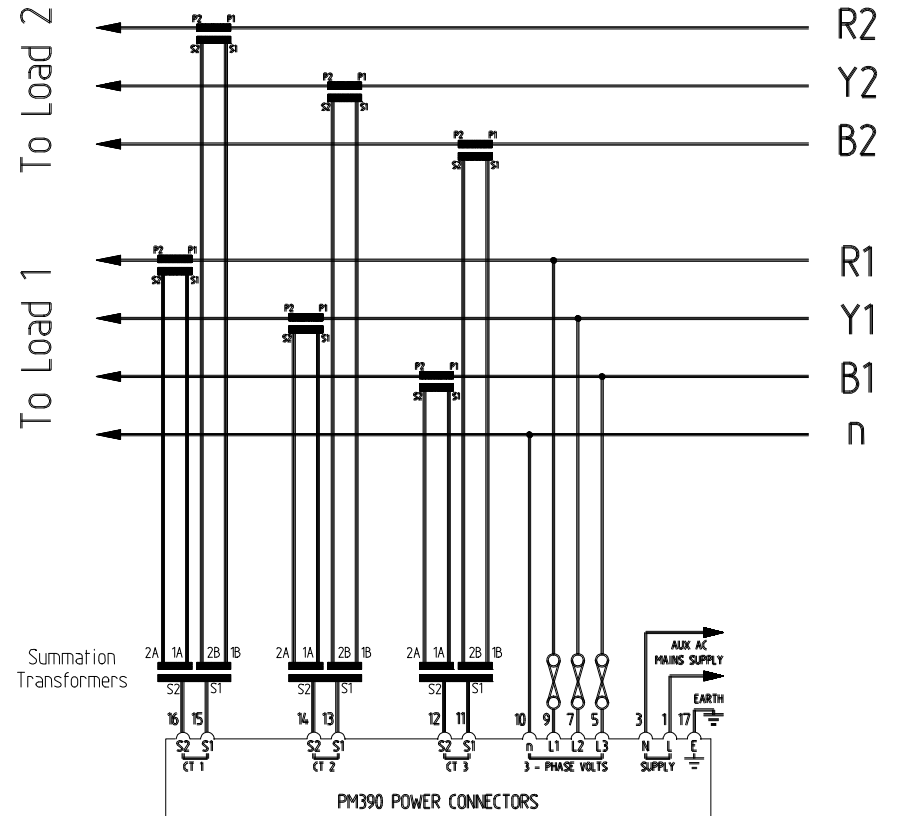

Figure 3.9 Schematic Adding Two Loads

### 4. Isolated Relay Outputs (Optional)

#### 4.1 General Description

Two isolated relay outputs are optionally available on the PM390. These may be programmed independently to provide pulse outputs or alarms as described in section 6.9. If fitted this will be indicated on the instrument label.

#### 4.2 Pulse Outputs

Each relay may be set-up to close momentarily for each increment of an associated energy register. Programming, described in section 6.9.1, allows selection of any available energy register, the pulse rate and closure period. Selectable parameters are limited to those available for display by the meter. Programming flexibility provides a low cost solution in a variety of applications including :

- ◆ **Abacus meter data collectors/loggers**
- ◆ **Remote energy counters**
- ◆ **Energy Management Systems**
- ◆ **Data loggers**
- ◆ **Monitoring and Targeting Systems**

#### 4.3 Alarm Outputs

Each relay may be set-up to close on the occurrence of a preset alarm condition. An alarm condition occurs when a chosen instantaneous parameter is greater than (or less than) a set value for a period greater than a given time delay. Selectable parameters are limited to those available for display by the meter. Programming allows selection of an instantaneous parameter, over or under alarm condition, alarm level, and delay. Programming is described in detail in section 6.9.2.

<p><b>NOTE</b> : Low power reed relays are used in the meter to provide long life. These <b>ARE NOT SUITABLE FOR DIRECT SWITCHING OF MAINS LOADS</b>. Interposing power relays may be externally fitted if required.</p>
--

#### 4.4 Connecting The Relays

The relays are isolated (to 2.5kV) from all other parts of the meter circuit and to 50V from each other. Each contact pair is normally open and has a maximum on resistance of 10Ω.

The relays are terminated on the rear panel of the PM390 at terminal numbers 23-24 (RI A) and 21-22 (RI B).

The cable used to connect external systems to the relays should be rated to suit the maximum current and voltage expected. It is recommended that screened twisted pairs are used in order to improve electro-magnetic compatibility.

The diagram below shows connection of the relay circuits

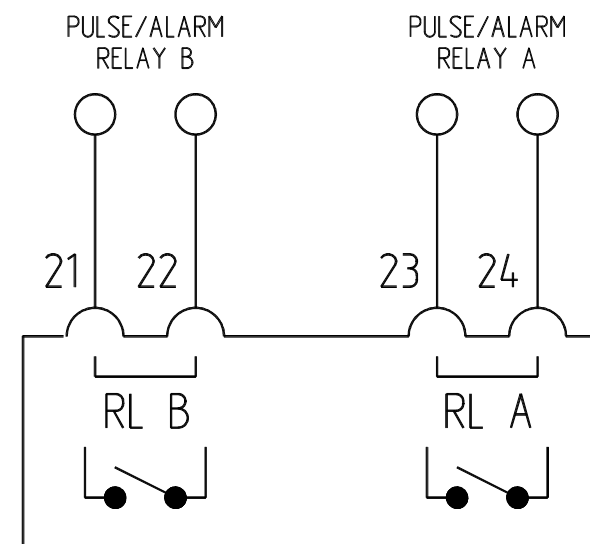

**Figure 4.1 Relay Output Connection**

## **Analogue Outputs**

---

### **5. Analogue Outputs (Optional)**

#### **5.1 General Description**

Two isolated analogue outputs are optionally available on a meter. The 'Dual Analogue Output' option must be specified at the time of order. If fitted this will be indicated on the instrument label.

The analogue outputs provide isolated d.c. current signals in proportion to any available instantaneous parameter. These signals may be fed into data loggers, chart recorders, BEMS, etc. as required.

The outputs may be scaled independently as described in section 6.12

## 5.2 Connecting The Analogue Outputs

The analogue output circuits may be configured to provide a 0-16mA or a 4-20mA signal in proportion to the full operating range of the selected input parameter (e.g. kW). The method of external connection determines which type of signal is output.

### 5.2.1 Connecting for 4-20mA Outputs

This method of connection is commonly used where output signals require transmission over relatively long cables.

The meter **SINKS** a current from an external d.c. voltage source (nominally 24V) dependant on the level of measured input signal. The voltage source is normally provided by the external measurement system (**LOOP** powered).

A single pair of wires are required for each output as shown below :

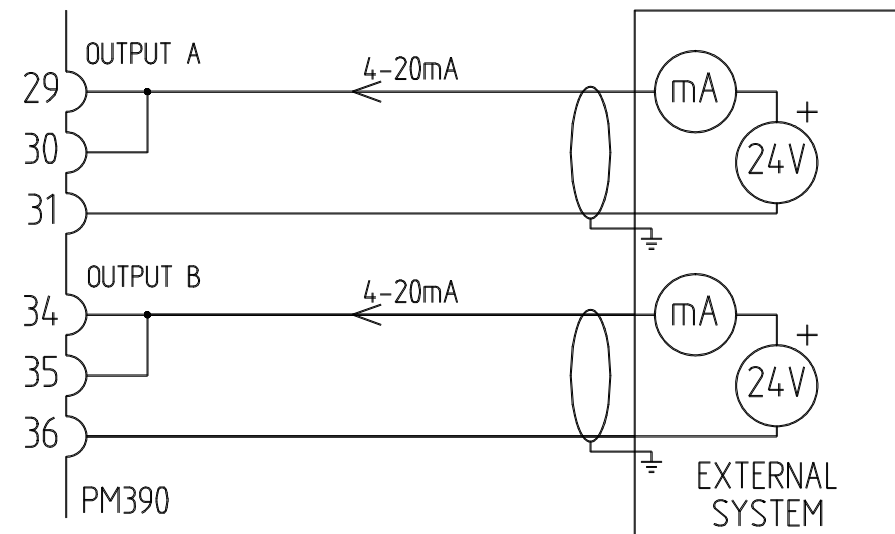

Figure 5.1 Connecting for 4-20mA Outputs

## Analogue Outputs

### 5.2.2 Connecting for 0-16mA Outputs

This method of connection is commonly used to generate local dc voltage outputs by connection of an external resistor. By choosing the correct resistor the voltage level may be selected. A  $312\Omega$  resistance for example will provide an output of 0-5V dc.

Connection to an internally generated dc supply (18V nominal) is required to provide isolated power to the output circuit as shown below.

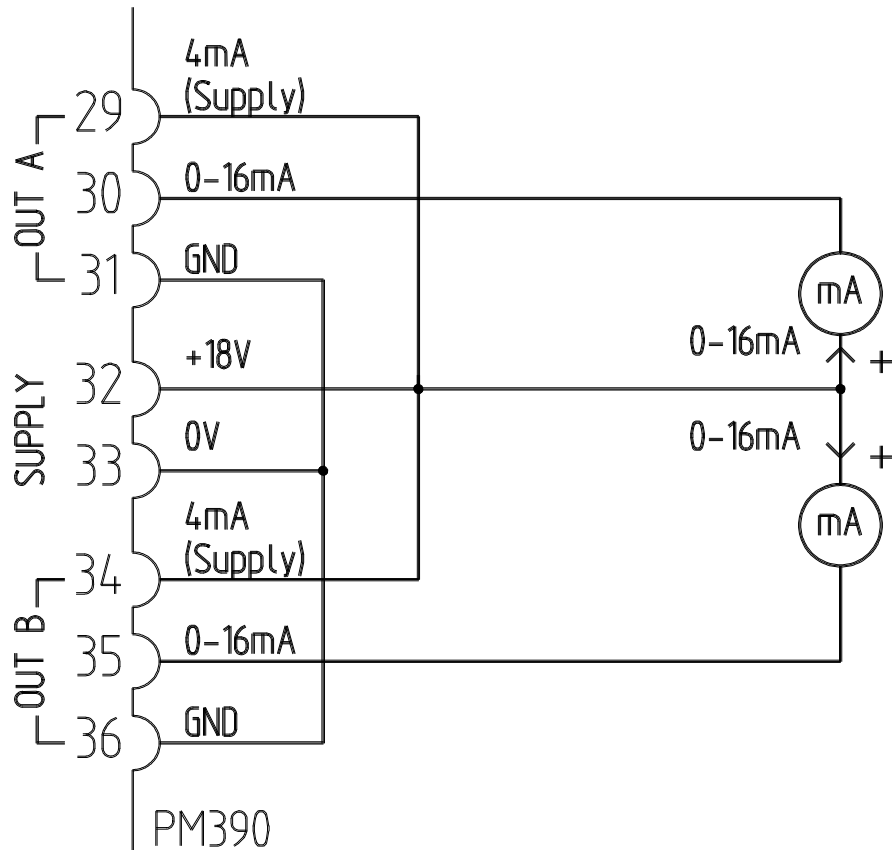

Figure 5.2 Connecting For 0-16mA Outputs

## 6. Programming

### 6.1 Description

The PM390 provides many features which may be programmed by the user to suit a specific application. Programming operations are available in a special mode selected using the front panel keys. Programmed parameters are stored in non-volatile memory and are therefore retained in the event of power failure to the equipment. Table 6-1 describes operations made available in programming mode. Certain operations are only available if an individual instrument has the relevant option fitted (e.g. analogue output).

#	Programming Operation	Note
1	Set current transformer primary rating (0.1A to 5000.0A)	1
2	Set potential transformer ratio (0.1:1 to 1000.0:1)	1
3	Reset all energy registers simultaneously to 0	1
4	Set relay output A parameters (Pulse output or Alarm settings)	2
5	Set relay output B parameters (Pulse output or Alarm settings)	2
6	Toggle CT Auto Rotation (ON or OFF)	1, 3
7	Toggle balanced voltage mode (ON or OFF)	1, 5
8	Set analogue output A (Parameter, scaling and range)	4
9	Set analogue output B (Parameter, scaling and range)	4
10	Set the Modbus address and serial comms speed	7
11	Set the real time clock.	6
12	Set MD integration period (5, 10, 15, 20 or 30 minutes)	6
13	Reset Maximum Demand registers to 0 (kVA MD and kW MD)	6
14	Return To Metering Mode ("All done setup")	1

**Table 6-1 Programming Mode Options**

**NOTES :**

- 1.Available as standard on all meters.
- 2.Available only on meters with dual relay output option fitted
- 3.Refer to section 2.9 for description of CT. Auto Rotation.
- 4.Available only on meters with analogue output option fitted.
- 5.Refer to section 2.10 for description of balanced voltage mode
- 6.Available only on meters with Maximum Demand option fitted.
- 7.Available only on meters with a communications option fitted.

# Programming

---

## 6.2 Entering Programming Mode

To enter programming mode press the **PROG** keys and hold for approximately 5 seconds. The display will show 'CHNG PROG SETUP'. Release the keys to enter the programming menu at 'ct Pri'. This is entry number 1 in the options menu, used to set the current transformer primary current rating.

**NOTE** : All power measurement is suspended when in programming mode.



## 6.3 Selecting Programming Options

Options described in Table 6-1 are selected from the programming menu using the **NEXT** or **PREV** keys. Details of how to make changes using each option are given in the following sections.

## 6.4 Exiting Programming Mode

To return to the normal measurement mode select 'ALL DONE SETUP' from the programming menu and press the **PROG** keys. The display shows 'SET DATA STORED' and then returns to normal measurement mode.



### 6.5 Disabling Programming

Access to the programming menu may be disabled by fitting a wire link between pins 19-20 (PROG DISABLE) on the rear panel of the meter.

**WARNING**

Meter inputs should be isolated before carrying out any wiring. Installation and maintenance should only be carried out by qualified personnel.

## 6.6 Setting The CT. Primary Current

This option applies a scaling factor to measurements made by the meter to take account of current transformers (CTs) which may be installed. The nominal primary current rating of the CT is used to multiply readings in the meter's software.

Enter programming mode as described above. Use the **NEXT** or **PREV** keys to select option 1, 'Ct Pri' from the menu. The bottom line of the display shows the CT primary rating in amps.

To adjust the setting **Press and Hold** the **PROG** keys until the current setting flashes. Use the **UP** or **DOWN** keys to increment or decrement the value. As a key is held down the speed at which the value changes increases progressively. Release the key momentarily to revert to the slowest speed.

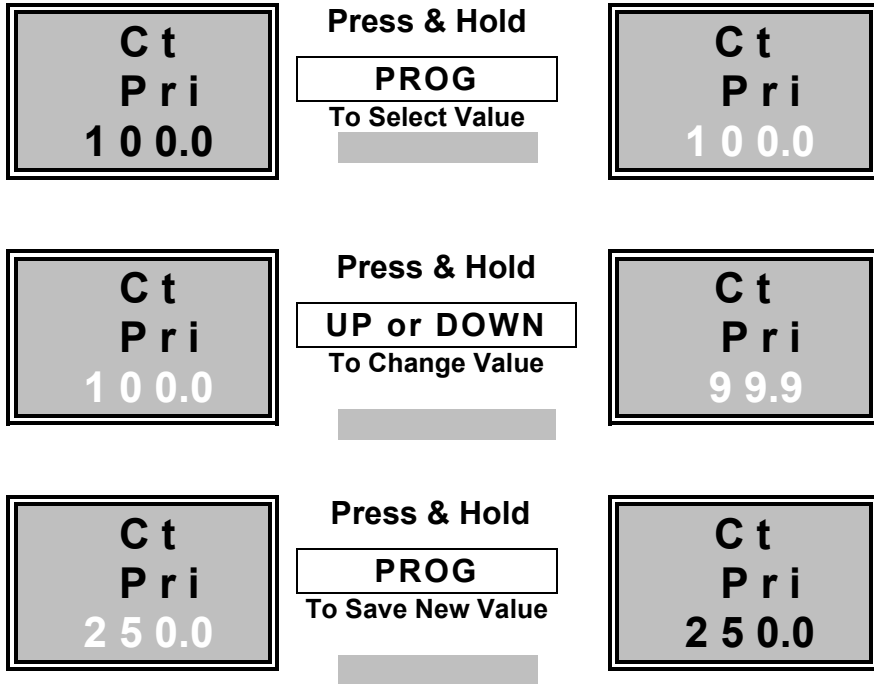

Press and hold the **PROG** keys when the desired CT primary current is displayed. The new value is now stored in non volatile memory and will take effect in all future measurements.

### 6.7 Setting The PT. Ratio

This option applies a scaling factor to measurements made by the meter to take account of voltage (potential) transformers (PTs) which may be installed. The nominal primary/secondary ratio of the PT is used to multiply readings in the meter's software.

Enter programming mode as described above. Use the **NEXT** or **PREV** keys to select option 2, 'Pt SCAL' from the menu. The bottom line of the display shows the PT ratio.

To adjust the setting, **Press and Hold** the **PROG** keys until the ratio value flashes. Use the **UP** or **DOWN** keys to increment or decrement the value. As a key is held down the speed at which the value changes increases progressively. Release the key momentarily to revert to the slowest speed.

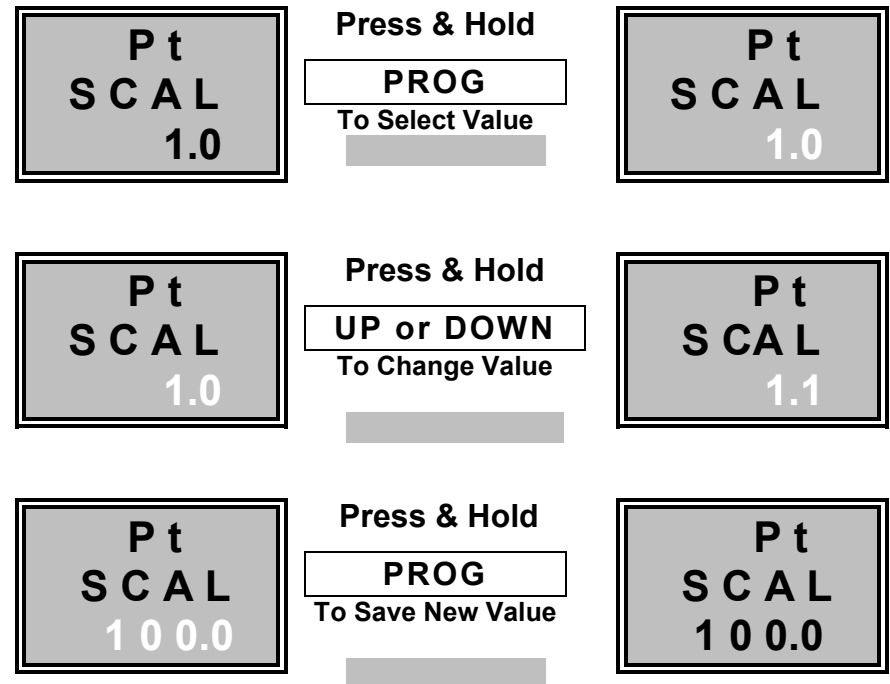

Press and hold the **PROG** keys when the desired PT ratio is displayed. The new value is now stored in non volatile memory and will take effect in all future measurements.

# Programming

## 6.8 Reset Energy Registers

This option resets all accumulated energy registers (kWh, kVAh, kvarh etc.) simultaneously to zero. The maximum demand registers, if available, are not affected.

**NOTE :** This operation is **NON-RECOVERABLE** and accumulated energy register data will be lost.

Enter programming mode as described above. Use the **NEXT** or **PREV** keys to select option 3, 'rSt ALL REGS' from the menu. Press the **PROG** keys to start the reset sequence. The bottom line of the display shows, 'In 5' which indicates a count down value, in seconds, to an actual reset. **Press and Hold** the **RESET** keys for 5 seconds to complete the reset operation.

As the reset sequence progresses the count down value decrements to the actual reset event. If at any time during this count down sequence the keys are released the process is aborted and the counter is reset to 5 seconds.

On completion of reset the registers are set to zero and the display confirms this with a message 'rSt REGS dOnE'.

To exit the reset option at any time press and hold the **PROG** keys.

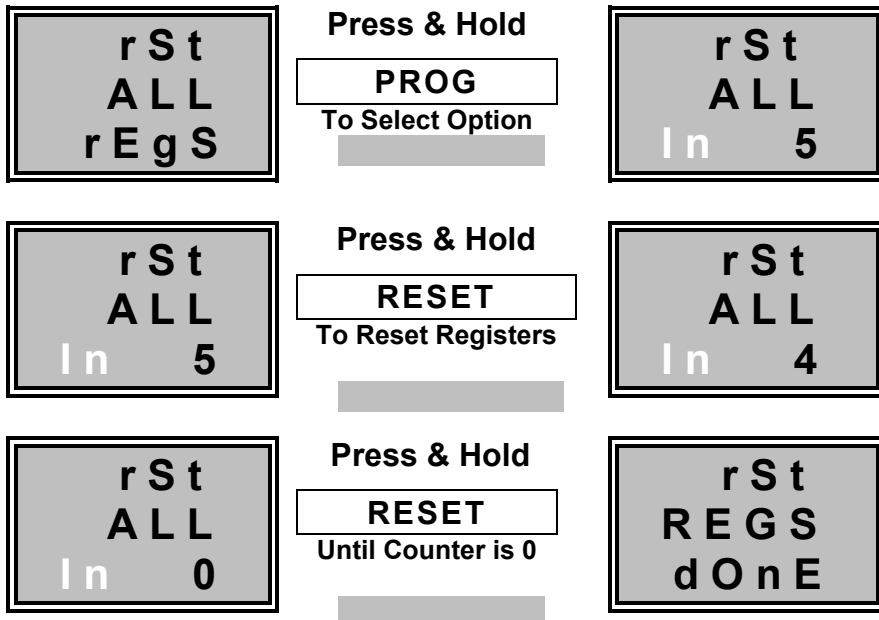

## 6.9 Relay Output Set-up

Two isolated signal relays are optionally provided on the PM390. These are referred to as 'RLA A' and 'RLA b'. A relay may be individually programmed as a pulse output or an alarm as required by the user. Connection to the relays is covered in section 4.

### 6.9.1 Programming a Relay as a Pulse Output

Relays may be set up to provide a short volt free contact closure for each increment of any one of the available energy registers. Programming allows the closure period and the rate at which pulses occur to be set.

The closure period ('on time') may be set in the range 100mS to 5.0 seconds. A relay may be set to pulse at a maximum rate of one pulse for each increment of the register and a minimum rate of one pulse for each 10,000 increments.

<i>Register</i>	<i>Menu Selection</i>		
<b>3-Phase kWh</b>	PLS PER		1.0 kWh
<b>3-Phase kVAh</b>	PLS PER		1.0 kVAh
<b>3-Phase Inductive kvarh</b>	PLS PER	L	1.0 kvarh
<b>3-Phase Capacitive kvarh</b>	PLS PER	C	1.0 kvarh
<b>3-Phase Export kWh</b>	PLS PER	E	1.0 kWh
<b>3-Phase Export kVAh</b>	PLS PER	E	1.0 kVAh

Note : The displayed pulse rate will vary according to user setting.

**Table 6-2 Pulse Programmable Relay Parameters**

For example Relay A may be set to provide a 100mS pulse for each 10 kWh accumulated. This signal could be used as an input to a building management system, data logger, etc.

## Programming

---

Enter programming mode as described above. Use the **NEXT** or **PREV** keys to select option 4 or option 5, 'SET RLA OUT A' or 'SET RLA OUT B' from the menu. Press the **PROG** keys to initiate the relay programming sequence.

The top line of the display (flashing) shows the relay's current mode of operation (pulse or alarm). Press and hold the **UP or DOWN** key until 'PL A' or 'PL B' is displayed. This indicates that the relay will operate as a pulse output.

The display now shows the current settings for a pulse output relay. The middle line of the display shows the duration of each pulse in seconds and the bottom line shows the amount of energy associated with each pulse. The legends on the right hand side of the display indicate which register is associated with the pulse output. For example :

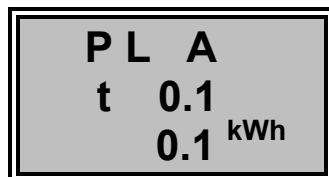

Relay A = pulse output

Pulse duration 100mS

1 Pulse every 0.1 kWh

Press the **NEXT** or **PREV** keys to select a parameter which requires changing. The selected parameter flashes. A selected parameter may be changed by pressing the **UP or DOWN** key repeatedly until the required value is displayed. When all changes are made the **PROG** keys are used to confirm the setting and return to the main programming menu.

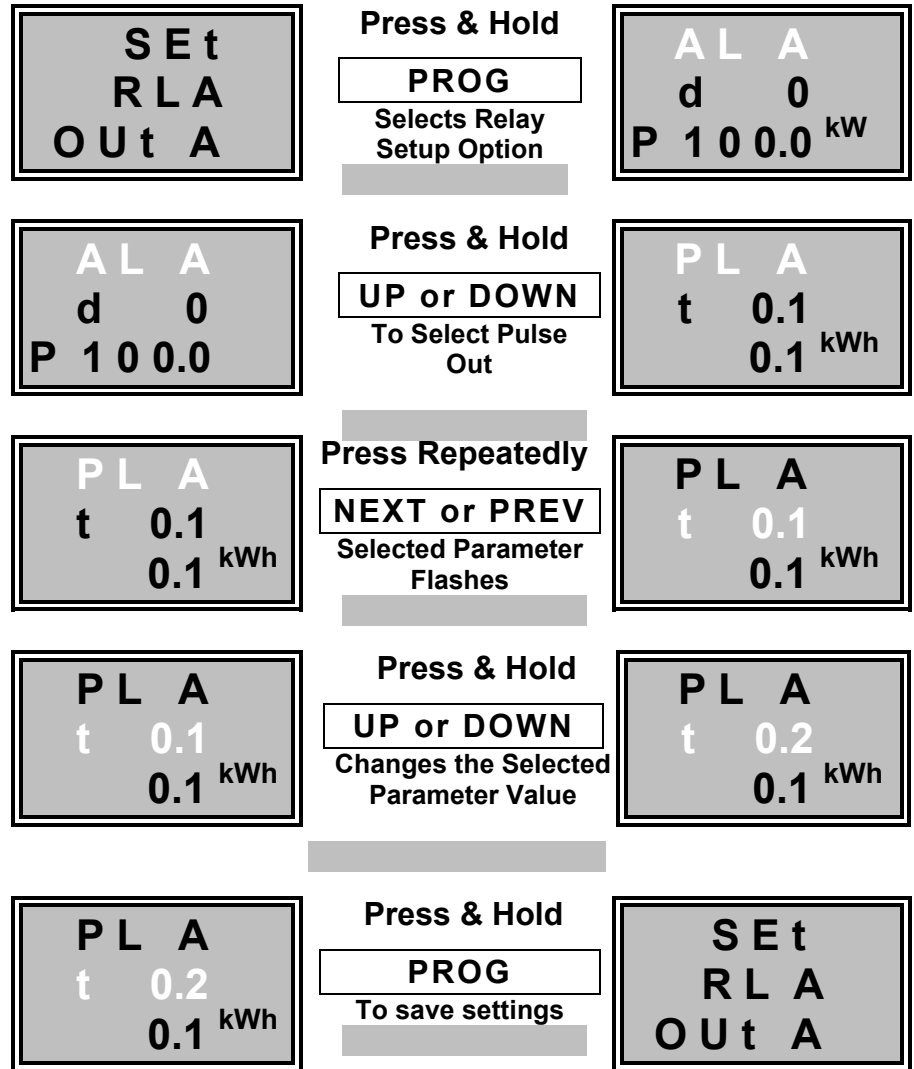

## 6.9.2 Programming a Relay as an Alarm

Relays may be set up to provide an alarm condition when a measured parameter is lower (under alarm) or higher (over alarm) than a specified value. The relays operate as normally-open isolated (voltage free) contacts. Programming allows the alarm type, level and delay to be set. The delay defines the time in seconds over which an alarm condition must be true before the relay contacts are closed. This value is variable in the range 1 to 10 seconds.

The alarm level is programmed as a percentage of full scale (except frequency which is set as Hz) of the selected measurement. Full scale values may depend on CT, PT and nominal meter ratings. Nominal full scale measurement values are described in Appendix A on page 88. The range of programmable full scale values is -120% to +120% for most parameters allowing alarms to be set for negative or positive measured values.

**Power Factor** alarms use only the **absolute** value of the measurement and ignore the sign. For example an under alarm set to trip at 80% Full scale PF, will operate for capacitive or inductive loads with power factors less than 0.8. A relay may be linked to a range of instantaneous measurements dependant on the instrument model. A complete list of parameters which may be available on a given meter model is shown in Table 6-3.

<i>Measurement</i>	<i>Range</i>
<b>3-Phase kW</b>	±120.0%
<b>3-Phase kVA</b>	±120.0%
<b>3-Phase kvar</b>	±120.0%
<b>3-Phase Average Voltage</b>	±120.0%
<b>3-Phase Average Current</b>	±120.0%
<b>3-Phase Absolute PF</b>	1.0% to 100.0%
<b>Frequency</b>	45.0 to 65.0 Hz
<b>kW Maximum Demand</b>	±120.0%
<b>kVA Maximum Demand</b>	±120.0%

Note : The displayed alarm level will vary according to user setting.

**Table 6-3 Programmable Alarm Relay Parameters**

**Example 1 :**

An alarm is required to indicate that the average 3-phase voltage has exceeded 250.0V.

The meter has a rated nominal voltage of 240.0V and the PT is programmed as 1:1.

The nominal full scale voltage is  $1 \times 240.0 = 240.0$ .

An over alarm is required at 104.2% of full scale nominal volts.

**Example 2 :**

An alarm is required to indicate that the average current has dropped below 10.0A. The meter has a rated nominal current of 100.0A programmed as the CT primary.

An under alarm is required at 10.0% of full scale nominal amps.

**Example 3 :**

An alarm is required to indicate when the meter detects a significant capacitive load. The kvar reading is ideal for this purpose as it's value swings positive to negative as the load changes from inductive to capacitive.

A level of -5% full scale is assumed by the user to be significantly capacitive. An under alarm is therefore required at -5% of full scale nominal kvar.

## Programming

---

Enter programming mode as described above. Use the **NEXT** or **PREV** keys to select option 4 or option 5, 'SET RLA OUT A' or 'SET RLA OUT B' from the menu. Press the **PROG** keys to initiate the relay programming sequence.

The top line of the display (flashing) shows the relay's current mode of operation (pulse or alarm). For an **OVER ALARM** Press and hold the **UP or DOWN** key until 'AL A' or 'AL B' is displayed. For an **UNDER ALARM** Press and hold the **UP or DOWN** key until '-AL A' or '-AL B' is displayed.

The display now shows the current settings for an alarm output relay. The middle line of the display shows the alarm delay in seconds and the bottom line shows the Percentage of full scale at which the alarm will be activated. The legends on the right hand side of the display indicate which measured parameter is associated with the alarm output. For example :



The display shows three lines of text: '-AL A' on the top line, 'd 5' on the middle line, and 'P 50.0 A' on the bottom line. The top line is enclosed in a double-line border.

Relay A = Under Alarm  
Alarm Delay 5 Seconds  
Alarm under 50% f.s Amps

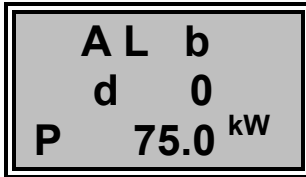

The display shows three lines of text: 'AL b' on the top line, 'd 0' on the middle line, and 'P 75.0 kW' on the bottom line. The top line is enclosed in a double-line border.

Relay B = Over Alarm  
No Alarm Delay  
Alarm over 75% f.s kW

Press the **NEXT** or **PREV** keys to select a parameter which requires changing. The selected parameter flashes. A selected parameter may be changed by pressing the **UP or DOWN** key repeatedly until the required value is displayed. When all changes are made the **PROG** keys are used to confirm the setting and return to the main programming menu.

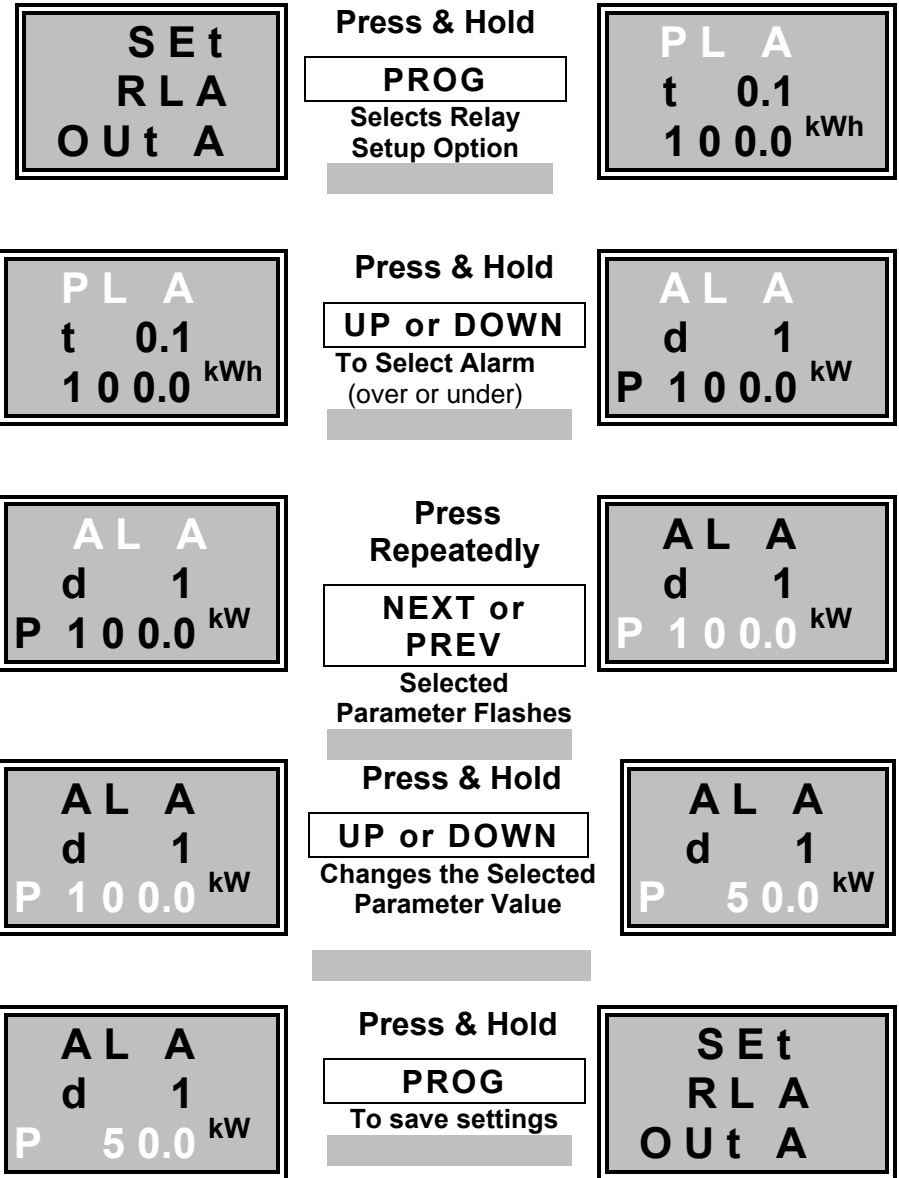

# Programming

## 6.10 Toggle CT Auto Rotation

'CT Auto Rotation', provides software correction for CT inputs which are connected in anti-phase. This allows the most common of installation errors to be corrected without expensive re-commissioning work or shut down. Full details on the recommended use of CT Auto Rotation is provided in section 2.9.

Meters are shipped with Auto Rotation enabled as default. The programming option allows CT Auto Rotation to be switched **ON** or **OFF** as required. Enter programming mode as described above. Use the **NEXT** or **PREV** keys to select option 6, 'AUTO Ct ON' or 'AUTO Ct OFF' from the menu.

Press the **PROG** keys to select the programming option. The bottom line 'ON' or 'OFF' flashes to indicate that it may be changed. Press **UP** or **DOWN** to toggle Auto CT Mode as required.

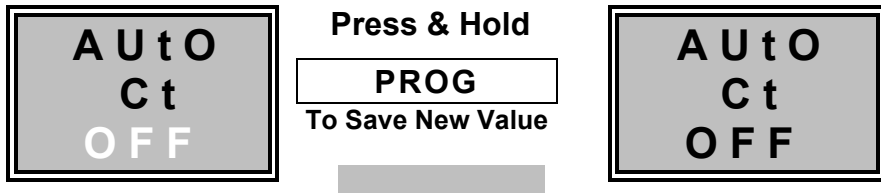
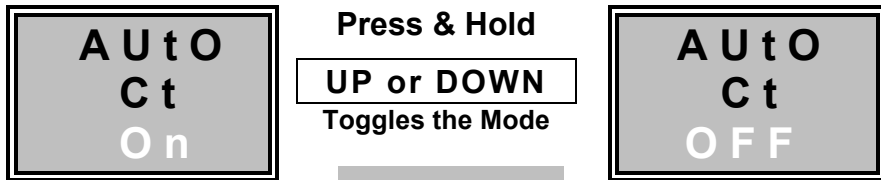
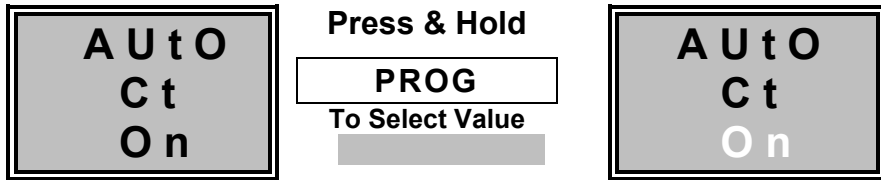

### **6.11 Toggle Balanced Voltage Mode**

Balanced voltage mode allows a meter to approximate full three phase measurement using three current inputs but only a single (Phase 1) voltage. This is described in more detail in Section 2.10.

Balanced voltage mode assumes that phase 2 and 3 voltages and power factors are equal to those of phase 1. It is recommended that this option is used in only extreme cases where it is not possible to obtain all three voltages for measurement input.

One example of the use of this connection is where a portable meter set is constructed using the PM390 as the main measurement element. The phase 1 voltage may then be connected in parallel with the meter auxiliary supply and picked up from a single phase mains supply.

This programming option allows Balanced Voltage Mode to be switched **ON** or **OFF** as required. As default, the meter is supplied with Balanced Voltage Mode switched OFF. Enter programming mode as described above. Use the **NEXT** or **PREV** keys to select the, '3-PH VOLT UNBAL' or '3-PH VOLT BAL' from the menu.

**Press** the **PROG** keys to select balanced voltage setup mode. Use the **UP** or **DOWN** keys to toggle the setting. Press and Hold the **PROG** keys to confirm the setting and to return to the main programming menu.

# Programming

---

3 - P h  
V O L t  
U n b A L

Press & Hold

PROG

Enters Setup Mode



3 - P h  
V O L t  
U n b A L

3 - P h  
V O L t  
U n b A L

Press & Hold

UP or DOWN

Toggles the Mode



3 - P h  
V O L t  
b A L

3 - P h  
V O L t  
b A L

Press & Hold

PROG

To Save New Value



3 - P h  
V O L t  
b A L

### 6.12 Analogue Output Set-up

Two isolated analogue output signals are optionally provided (see instrument label for details). These are referred to as 'ANAL A' and 'ANAL b'. Each output may be individually programmed to provide an analogue signal proportional to a measured instantaneous value.

External wiring configuration provides outputs of **4-20mA** or **0-16mA** as required. Connection of the analogue output channels is described in section 5. Programming allows the input parameter, input range and output scale to be defined.

A range of **Input Parameters** may be linked to an analogue output. Only parameters measured by each meter model are made available for output. Table 6-4 shows the maximum number of parameters.

<i>Instantaneous Parameter</i>	<i>Menu Display Selection</i>
<b>3-Phase Power Factor</b>	<b>3-Ph PF</b>
<b>Frequency</b>	<b>Ph 1 HZ</b>
<b>3-Phase kW</b>	<b>3-Ph kW</b>
<b>3-Phase kVA</b>	<b>3-Ph kVA</b>
<b>3-Phase kvar</b>	<b>3-Ph kVAr</b>
<b>Average Volts (V1+V2+V3)/3</b>	<b>AVE V</b>
<b>Average Amps (I1+I2+I3)/3</b>	<b>AVE A</b>
<b>Phase 1 Volts</b>	<b>Ph 1 V</b>
<b>Phase 2 Volts</b>	<b>Ph 2 V</b>
<b>Phase 3 Volts</b>	<b>Ph 3 V</b>
<b>Phase 1 Amps</b>	<b>Ph 1 A</b>
<b>Phase 2 Amps</b>	<b>Ph 2 A</b>
<b>Phase 3 Amps</b>	<b>Ph 3 A</b>
<b>Accumulating kW MD.</b>	<b>3-Ph kW MD</b>
<b>Accumulating kVA MD.</b>	<b>3-Ph kVA MD</b>

Table 6-4 Analogue Output Parameters

## Programming

---

The **Input Range** defines how the software handles positive and negative instantaneous meter readings before they are sent to the analogue output.

- The **Unipolar** range provides analogue output of positive readings only. Negative values are set to zero before processing by the output circuit.
- The **Bipolar** range allows output of positive and negative readings. A reading of zero is positioned at the mid point of the output range.
- The **Absolute** range provides output of the instantaneous value only, ignoring the sign. Figure 6.1 to Figure 6.3. show the characteristic graphs for each input range.

The effect of selecting between input ranges is shown in the graphs below.

The **Output Scale** (percentage of full scale) setting enables the user to define a level of measured signal to represent full scale output (16mA or 20mA). The range of output scaling is 50.0% to 200.0% of the nominal full scale for the chosen parameter.

### Example 1

The user in this case has a CT primary of 200A. An analogue output of 4-20mA is required, to represent 0-150 Amps (0-75% FS) on the phase 1 only :  
The output connection is set to provide 4-20mA. A **Unipolar** input range is selected because the current is always positive.

**Un A, Ph 1 A, P 75.0** is programmed. The parameter is set to phase 1 amps and the 20mA signal set to represent 75% of 200.0 Amps (150.0A) as required.

### Example 2

The user requires an analogue output of 4-20mA to represent -36kW to +36kW. Negative kW in this case represents power exported from the measured load into the supply.

The user in this case has a nominal voltage of 240.0V, a PT setting of 1:1 and a CT primary of 100A. The nominal full scale kW is calculated as  
 $3 \times 240 \times 1 \times 100 = 72.0 \text{ kW}$ .

The output connection is set to provide 4-20mA. A **Bipolar** input range is selected because the power may be positive or negative.

**Bi A, 3-Ph kW, P 50.0** is programmed. The parameter is set to three phase kW and the 20mA signal set to represent 36.0 kW (50% of 72.0kW) as required.

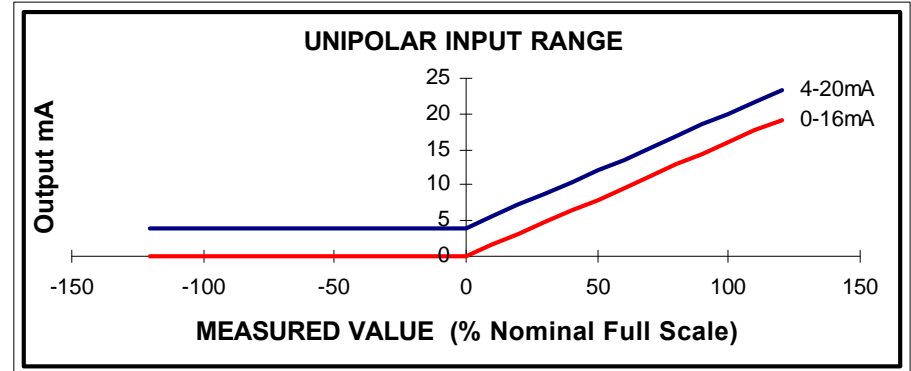

Figure 6.1 Unipolar Analogue Output

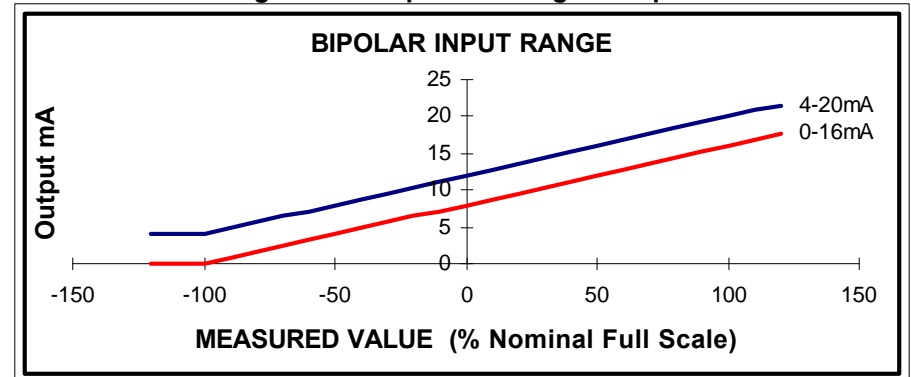

Figure 6.2 Bipolar Analogue Output

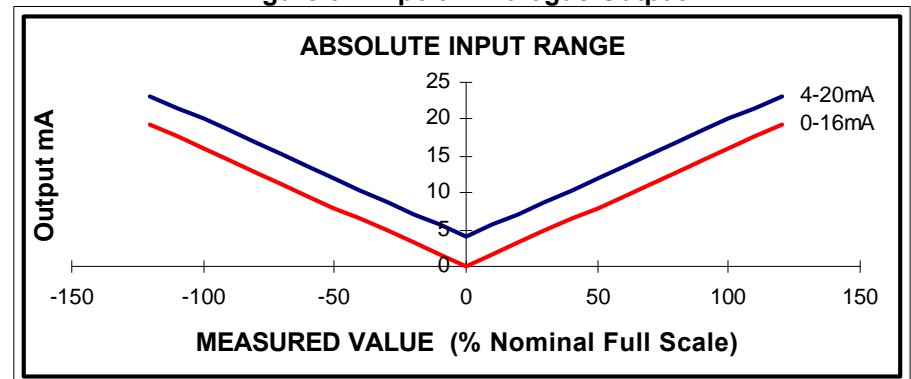

Figure 6.3 Absolute Analogue Output

## Programming

Enter programming mode as described above. Use the **NEXT** or **PREV** keys to select 'SET AnAL OUT A' or 'SET AnAL OUT b' from the menu. Press the **PROG** keys to initiate the relay programming sequence.

The display now shows the current settings for the chosen analogue output channel. The top line shows the input range as **Un** (Unipolar), **Bi** (Bipolar) or **Ab** (Absolute). The middle line of the display, along with the legend on the right hand side, shows the output parameter and the bottom line shows the Percentage of full scale which will provide 20mA (4-20mA) or 16mA (0-16mA) out. For example

:

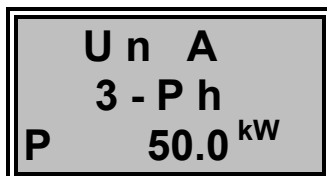

Un A  
3 - Ph  
P 50.0 kW

Output A = Unipolar Input  
3-Ph kW Selected  
20mA/16mA = 50% f.s kW

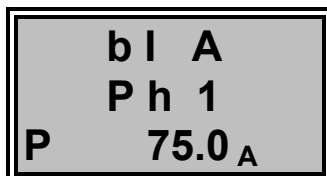

bi A  
Ph 1  
P 75.0 A

Output A = Bipolar Input  
Phase 1 Amps Selected  
20mA/16mA = 75% f.s I<sub>1</sub>

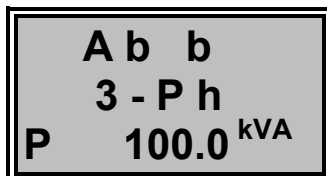

Ab b  
3 - Ph  
P 100.0 kVA

Output b = Absolute Input  
3-Ph kVA Selected  
20mA/16mA=100% f.s kVA

Press the **NEXT** or **PREV** keys to select a parameter which requires changing. The selected parameter flashes. A selected parameter may be changed by pressing the **UP** or **DOWN** key repeatedly until the required value is displayed. When all changes are made the **PROG** keys are used to confirm the setting and return to the main programming menu.

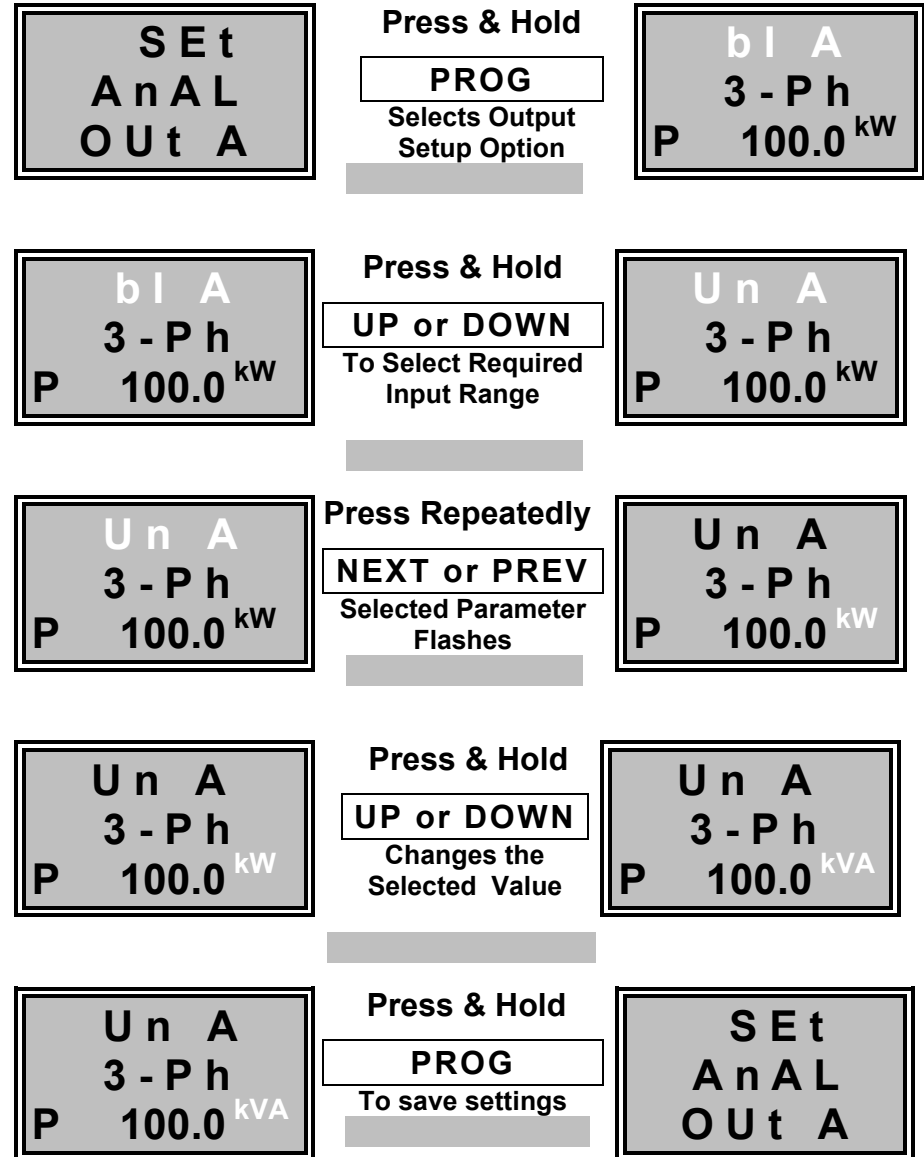

# Programming

---

## 6.13 Setting The Meter Communication Channel

This option, only available on meters with serial communications, allows the Modbus address and data speed (baud rate) to be set. The address, used by the host computer to identify an individual meter may be set in the range 1-247. The baud rate (bits per second) may be set, in the range 2400 to 19200 to suit the optimum speed of communication for the host system.

<b>S E t U P S E R I A L</b>	<b>Press &amp; Hold</b> <div style="border: 1px solid black; padding: 2px; text-align: center; margin: 5px 0;"><b>PROG</b></div> Selects Comms Setup Option	<b>A d d r</b>  2 5 <b>b 9 6 0 0</b>
--------------------------------------	---	---

<b>A d d r</b>  2 5 <b>b 9 6 0 0</b>	<b>Press Repeatedly</b> <div style="border: 1px solid black; padding: 2px; text-align: center; margin: 5px 0;"><b>NEXT or PREV</b></div> To select (flashes) address/ baud rate	<b>A d d r</b>  2 5 <b>b 9 6 0 0</b>
---	---	---

<b>A d d r</b>  2 5 <b>b 9 6 0 0</b>	<b>Press &amp; Hold</b> <div style="border: 1px solid black; padding: 2px; text-align: center; margin: 5px 0;"><b>UP or DOWN</b></div> Changes the Selected Value	<b>A d d r</b>  2 5 <b>b 4 8 0 0</b>
---	---	---

<b>A d d r</b>  2 5 <b>b 4 8 0 0</b>	<b>Press &amp; Hold</b> <div style="border: 1px solid black; padding: 2px; text-align: center; margin: 5px 0;"><b>PROG</b></div> To save settings	<b>S E t U P S E R I A L</b>
---	--	--------------------------------------

## 6.14 Setting The Real Time Clock (RTC)

This option is only available on meters fitted with an internal real time clock, for example meters monitoring Maximum Demand. The **Time** may be set to the nearest second as required.

The internal real time clock maintains time in the event of power fail by means of an internal lithium battery.

Enter programming mode as described above. Use the **NEXT** or **PREV** keys to select '**SET RTC**' from the menu. The bottom line of the display shows the current time in Hours Minutes and Seconds.

Press the **PROG** keys to enable the time setting mode. The **NEXT** and/or **PREV** keys may now be used to select **HOURS, MINUTES or SECONDS** for alteration. The selected value flashes. The **UP** and/or **DOWN** keys are used to adjust the selected value required.

The **PROG** keys are used to confirm the new time setting and the RTC is restarted from the new time as the keys are pressed.

**Programming**

---

**S E t**  
**R t C**  
**1 2:0 0:0 0**

**Press & Hold**

**PROG**  
Selects Set RTC  
\_\_\_\_\_

**S E t**  
**R t C**  
**1 2:0 0:0 0**

**S E t**  
**R t C**  
**1 2:0 0:0 0**

**Press Repeatedly**

**NEXT or PREV**  
Selected Parameter  
Flashes  
\_\_\_\_\_

**S E t**  
**R t C**  
**1 2:0 0:0 0**

**S E t**  
**R t C**  
**1 2:0 0:0 0**

**Press & Hold**

**UP or DOWN**  
Changes the  
Selected Parameter  
\_\_\_\_\_

**S E t**  
**R t C**  
**1 2:3 0:0 0**

**S E t**  
**R t C**  
**1 2:3 0:0 0**

**Press & Hold**

**PROG**  
To set new time  
\_\_\_\_\_

**S E t**  
**R t C**  
**1 2:3 0:0 0**

### 6.15 Setting The MD and Rolling Average Integration Period

This option allows the Maximum Demand and rolling average time period to be set as 5, 10, 15, 20 or 30 minutes. Maximum Demand periods are synchronised each day to 00:00:00 Hrs (midnight) on the internal real time clock (RTC). Rolling average periods are the most recent period ending at the last display update.

Enter programming mode as described above. Use the **NEXT** or **PREV** keys to select option 12, 'Set Per MD' from the menu. The bottom line of the display shows the present period in minutes.

To adjust the setting **Press and Hold** the **PROG** keys to select MD period programming mode. The MD period flashes indicating it may now be changed. The **UP** and/or **DOWN** keys may be used to select a new MD period. When the required value is displayed **Press and Hold** the **PROG** keys to confirm the setting.

# Programming

---

<b>SEt</b> <b>PEr</b> <sup>MD</sup> <b>30</b>	<b>Press &amp; Hold</b> <b>PROG</b> To Select Value	<b>SEt</b> <b>PEr</b> <sup>MD</sup> <b>30</b>
---	---	---

<b>SEt</b> <b>PEr</b> <sup>MD</sup> <b>30</b>	<b>Press &amp; Hold</b> <b>UP / DOWN</b> To Change Value	<b>SEt</b> <b>PEr</b> <sup>MD</sup> <b>20</b>
---	--	---

<b>SEt</b> <b>PEr</b> <sup>MD</sup> <b>20</b>	<b>Press &amp; Hold</b> <b>PROG</b> To Save New Value	<b>SEt</b> <b>PEr</b> <sup>MD</sup> <b>20</b>
---	---	---

### 6.16 Reset Maximum Demand and Rolling Average Registers

This option resets Stored kW , kVA MD, Peak Rolling kW and Peak Rolling kVA registers simultaneously to zero. The standard energy registers, are not affected.

**NOTE :** This operation is **NON-RECOVERABLE** and stored rolling average and MD register data will be lost.

Enter programming mode as described above. Use the **NEXT** or **PREV** keys to select option 13, '**RSt Peak MD REGS**' from the menu. Press the **PROG** keys to start the reset sequence. The bottom line of the display shows, '**In 5**' which indicates a count down value, in seconds, to an actual reset. **Press and Hold** the **RESET** keys for 5 seconds to complete the reset operation.

As the reset sequence progresses the count down value decrements to the actual reset event. If at any time during this count down sequence the keys are released the process is aborted and the counter reset to 5 seconds.

On completion of reset the MD associated registers are set to zero and the display confirms this with a message '**RSt REGS dOnE**'.

To exit the reset option at any time press and hold the **PROG** keys.

# Programming

---

rSt<sup>Peak</sup><sub>MD</sub>  
rEgS

Press & Hold  
**PROG**  
To Select Option

rSt<sup>Peak</sup><sub>MD</sub>  
In 5

rSt<sup>Peak</sup><sub>MD</sub>  
In 5

Press & Hold  
**RESET**  
To Reset  
Registers

rSt<sup>Peak</sup><sub>MD</sub>  
In 4

rSt<sup>Peak</sup><sub>MD</sub>  
In 0

Press & Hold  
**RESET**  
Until Counter is 0

rSt  
REGS  
dONE

## 7. Serial Communication

### 7.1 Introduction

The PM390 is optionally available with serial communications. This allows remote reading and programming of the meter by a host computer (eg PC). Either RS232 or RS485/422 may be fitted providing one-one or multi-drop configurations respectively. Details of the options fitted to an individual meter are provided on the instrument label.

The communication protocol used by the PM390 is a subset of Modicon's Modbus enabling use of standard host protocols and connection to standard controllers.

### 7.2 Communication Address

Each meter on a Modbus serial communication network must be assigned a unique address between 1 and 247. This is carried out in programming mode as described in Section 6.13. If two or more meters, connected to a multi-drop network have the same address, data on the network will be corrupted and communication will fail.

### 7.3 Data Format

The meter uses a fixed data format for serial communications :

<b>1 Start Bit</b>	<b>8 Data Bits</b>	<b>1 Stop Bit</b>
--------------------	--------------------	-------------------

The 8 data bits are always transmitted least significant bit first. This data byte is binary coded.

The baud rate is programmable as **2400, 4800, 9600, or 19200 baud**. This is carried out in programming mode as described in Section 6.13

### 7.4 RS232

RS232 allows connection of a single meter to a standard serial communication port of a host computer. This method of connection is reliable for distances up to 5 metres at 19,200 baud. For longer distances it may be necessary to reduce communication speed.

## Communications

---

### 7.4.1 RS232 Connection

It is recommended that screened cable is used with the screen grounded to the connector housing at the host only. The following table shows pin-out details for PC. compatibles with either 9 or 25 pin ports.

<b>RS232 (At PM390)</b>	<b>METER PIN NO.</b>	<b>9 PIN D-TYPE (On Standard PC)</b>	<b>25 PIN D-TYPE (On Standard PC)</b>
Receive	27	3 (Tx)	2 (Tx)
Transmit	25	2 (Rx)	3 (Rx)
0V	26	5 (0V)	7 (0V)

Table 7-1 RS232 Interface Pin-Out

### 7.5 RS485

The RS485 communication option enables connection of up to 32 meters on a single pair of wires (bus). The pair is used for transmission and reception with each meter (and the host) automatically switching data direction. The host should be fitted with an RS485 driver (or converter) capable of operation in two wire mode. Each serial transaction is preceded by a meter address allowing the host to temporarily connect with any meter on the bus. Certain commands allow the host to transmit commands or data to all meters simultaneously. These commands are known as **broadcasts** and use address 0. The RS485 standard enables reliable communication over a maximum distance of 1200 metres.

**Note** : Use of standard external RS485 bus repeaters allows connection of higher numbers of meters over longer distances.

### 7.5.1 RS485 Connection

It is recommended that screened twisted-pair cable is used for RS485 connection in order to minimise signal errors due to noise. The screen should be connected to the connector housing (ground) at the host only. To reduce cable reflections over long distances, RS485 systems require line termination. This is achieved by fitting two 120Ω terminating resistors as shown in Figure 7.1. One resistor should be fitted at the Host receive input buffer and the other at the receive buffer of the most remote meter.

<b>RS485 (At PM390)</b>	<b>PM390 PIN N0s</b>	<b>AT HOST</b>
<b>TX/RX +</b>	<b>Link 25-27</b>	<b>RS485 Positive</b>
<b>TX/RX-</b>	<b>Link 26-28</b>	<b>RS485 Negative</b>

Table 7-2 RS485 Interface Pin-Out

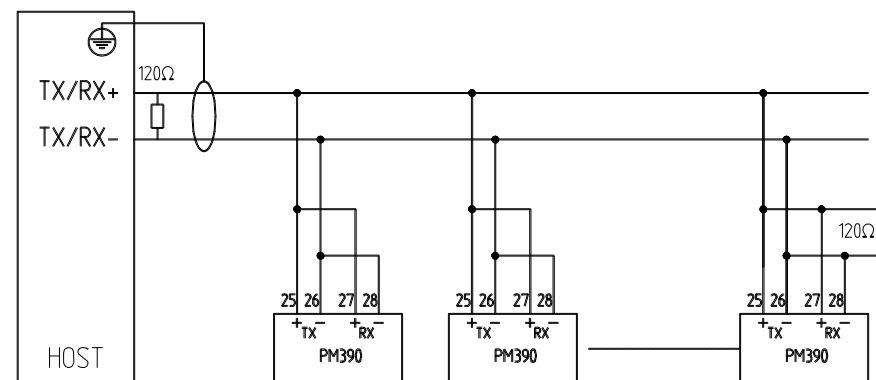

Figure 7.1 RS485 Multi-Drop Connection

# Communications

## 7.6 RS422

The RS422 communication option enables connection of up to 32 meters on two pairs of wires (4-wire bus). One pair is used for transmission and the other for reception.

RS422 may be used in systems where the host is not capable of operation in half duplex mode. The RS422 standard enables reliable communication over a maximum distance of 1200 metres.

### 7.6.1 RS422 Connection

It is recommended that screened 2 x twisted pair cable is used for RS422 connection in order to minimise signal errors due to noise. The screen should be connected to the connector housing (ground) at the host only

To reduce cable reflections over long distances, RS422 systems require line termination. This is achieved by fitting two 120Ω terminating resistors as shown in Figure 7.2. One resistor should be fitted at the Host receive input buffer and the other at the receive buffer of the most remote meter.

**Note :** Use of standard external RS422 bus repeaters allows connection of higher numbers of meters over longer distances.

<b>RS422 (At PM390)</b>	<b>PM390 PIN NOs</b>	<b>AT HOST</b>
<b>TX +</b>	<b>25</b>	<b>RS422 Receive Positive</b>
<b>TX -</b>	<b>26</b>	<b>RS422 Receive Negative</b>
<b>RX +</b>	<b>27</b>	<b>RS422 Transmit Positive</b>
<b>RX -</b>	<b>28</b>	<b>RS422 Transmit Negative</b>

Table 7-3 RS422 Interface Pin-Out

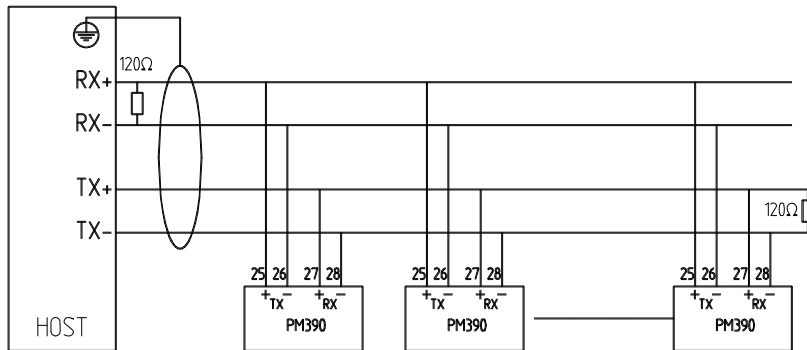

Figure 7.2 RS422 Multi-Drop Connection

## 7.7 Communication Protocol

### 7.7.1 An Introduction To Modbus

A communication protocol defines a set of commands and data formats which will be recognised by all compatible equipment connected on a system. The protocol effectively forms a communication language.

The PM390 meters utilise a subset of Modicon's 'Modbus' standard protocol. This protocol was originally developed for use by programmable logic controllers (PLCs). It defines a set of commands for reading and/or writing data to devices connected on the bus.

Modbus is a master-slave protocol with all transactions initiated by a single host (e.g. a PC). A single transaction commences with the host transmission of a command packet followed by a slave (meter) reply within 250mS of the end of the transmitted message.

Command packets consist of an address, a command identifier, data and a checksum for error detection. Each slave device continually monitors the bus looking for activity. Command packets are detected by all slaves but may be acted upon only by the device whose address matches that transmitted.

The host may transmit a **broadcast command** which uses address 0 to contact all devices on the network. In this instance the command is acted upon by all slaves but none of them may reply. This type of command may be useful, for example, in synchronising energy register reset on all meters.

The full Modbus protocol consists of many commands and modes of operation to suit a variety of controllers and applications. The PM390 utilises only a few commands and a single transmission mode to perform many functions specific to metering.

## 7.7.2 RTU. Transmission Mode

The RTU (Remote Terminal Unit) mode is utilised by the PM390 because it provides the most efficient throughput of data at any particular baud rate. In RTU mode, the start and end of each message is marked by a silent period of at least 3.5 character periods (Approx. 3.5mS @ 9600 baud). This is shown in the RTU message frame in Figure 7.3 below.

START	ADDRESS	FUNCTION	DATA	CRC	END
SILENT PERIOD	8 BITS	8 BITS	$n \times 8$ BITS	16 BITS	SILENT PERIOD

**Figure 7.3 RTU Framing**

The host (PC) initiates all transactions. Slave meters continuously monitor the network, looking for messages framed by silent periods. The first character detected, after a silent period, is assumed to be an address byte and is compared to the meters internal address (zero for broadcasts). An addressed slave reads the remainder of the message and acts upon it as required. A slave tests the message to determine its validity and uses the transmitted checksum (CRC) to detect communication errors. A slave will only reply to valid messages, received without error, specifically addressed to itself.

### ADDRESS

Valid Modbus addresses are in the range 0-247. Individual meters may be assigned addresses in the range 1-247. Address 0 is retained for broadcast commands which are handled by all slaves. When a slave responds to a command it places its own address in the reply message.

### FUNCTION

The function code is a single byte telling the meter what type of operation to perform. Valid Modbus codes are in the range 1-255 decimal but the PM390 handles only a small subset of these as summarised below.

Function code	Operation	Broadcast
04	Read Multiple Registers	No
06	Preset A Single Register	Yes
08	Loop Back Diagnostic	No
16	Preset Multiple Registers	Yes

**Figure 7.4 Function Code Summary**

### DATA FIELD

Data from the host contains additional information for the meter specific to the command. For example the data field may specify which meter readings are required or new values for energy registers.

Data from a slave may contain meter readings or other information requested by the host. The slave also uses the data field to transmit error codes (**exceptions**). The size of the data field varies depending on command type and usage. The data format may also vary from one command to another to suit the application. Instantaneous readings for example are transmitted as IEEE floating point numbers, whereas energy readings are formatted as 4-byte long integers. Data is always transmitted with the most significant byte first. Data formatting is described in more detail in the following sections.

### CRC ERROR CHECKING

A 16 bit CRC (*Cyclic Redundancy Check*) field is tagged on to the end of all messages. This field is the result of a CRC calculation performed on the message contents. The CRC field is used by the host and receiving devices alike to determine the validity of the entire message string. A receiving device recalculates the CRC and compares it to the value contained in the message. A slave device ignores a message if the two values do not match.

#### **Note**

Use of the CRC is essential when communicating in noisy environments to reduce the effects of erroneous bit errors. The meter will not reply to commands with a CRC in error and the host should re-transmit the command after a pre-determined time-out period. If the host receives a string with a CRC in error the transaction should be re-initiated.

The CRC is calculated on all bytes of a message from the address to the last data byte inclusively. Each bit of the message is processed through the CRC calculation starting with the first bit of the address. The Modbus standard method of CRC calculation requires reversal of the data bytes as they are fed serially through the bit processing routines. A simpler method involves swapping the low and high order bytes of the CRC integer at the end of the calculation. This is shown in the following routine.

## Communications

---

The calculation is performed as follows :

1. Load a 16 Bit register ("CRC Register") with FFFF Hex. (All 1's).
2. Exclusive-OR the first 8 Bits of the message with the low-order byte of the CRC register. Put the result in the CRC register.
3. Shift the CRC register one bit to the right (divide by 2), filling the MSB with a zero.
4. If the bit shifted out in 3 is a 1, Exclusive-OR the CRC register with the value A001 Hex.
5. Repeat steps 3 and 4 until 8 shifts have been performed and the bits tested. A single byte has thus been processed.
6. Repeat steps 2 to 5 using the next 8 bit byte of the message until all bytes have been processed.
7. The final contents of the CRC register is tagged on to the end of the message with the most significant byte first.
8. Swap the low and high order bytes of the integer result

An implementation of the CRC calculation in C code is shown below :

```
unsigned int check_sum(unsigned char *buff, char start, char bytes)
{
    char byte_cnt,bit_cnt;          /* loop counters */
    unsigned int crc_reg;           /* Result register */
    unsigned int CRCHI, CRCLo; /*Low and high order bytes of the crc*/

    crc_reg = 0xFFFF;              /* Set the CRC register to all 1's */

    /* Repeat for each byte of sub string */
    for(byte_cnt=start; byte_cnt<(bytes+start); byte_cnt++)
    {
        crc_reg = crc_reg ^ (unsigned int)buff[byte_cnt]; /*EXOR CRC & Next Byte*/

        /* Test each bit of the CRC */
        for(bit_cnt=0; bit_cnt<8; bit_cnt++)
        {
            if(crc_reg & 0x0001)
            {
                crc_reg = crc_reg >> 1; /* IF LSB=1 EXOR CRC with A001H */
                crc_reg = crc_reg ^ 0xA001; /* Then shift CRC toward LSB */
            }
            else crc_reg = crc_reg >> 1; /* ELSE Shift CRC towards LSB */
        }
    }
    CRCLo=crc_reg>>8; /*Swap the low and high order bytes of the crc result*/
    CRCHI=crc_reg<<8;
    crc_reg = CRCLo+CRCHI;
    return crc_reg;                /* Final CRC register Result */
}
```

---

**7.8 Data Tables**

Data in the PM390 is arranged in several tables for convenience. Individual tables contain like information. Table data may be read only (eg. Instantaneous readings) or read/write access (eg. CT primary).

Data in each table is addressed in a Modbus command by two consecutive bytes. The first byte defines the table number and the second byte the offset of the data in the table. For example, 'address 2 , 1' would access Table 2, Entry 1 (3-Phase kWh ). The Modbus standard defines data addresses using an integer. In the case of the PM390 the high byte of this integer is represented by the table number and the low byte by the offset. A Modbus integer address may be calculated as :

$$\text{Modbus Data Address} = (256 \times \text{Table No}) + \text{Table Offset}$$

The format of data in a table is defined to suit the type of information it holds. Table 1 for example uses floating point registers to hold instantaneous meter readings.

**INTEGERS (Int)**

Integers are 16 bit values transmitted as two 8 bit bytes. The most significant byte is always transmitted first. These values vary in the range -32767 to +32767 although some registers have a limited range of acceptable values. The most significant bit defines the sign, zero indicating positive.

**LONG INTEGERS (Long Int)**

Long Integers are 32 bit values transmitted as four 8-bit bytes. The most significant byte is always transmitted first. These values are limited to the range 0 to 9999999 for the PM390.

**FLOATING POINT (Float)**

Floating Point numbers are 32 bit values transmitted as four 8-bit bytes following the IEEE standard for floating point values. The most significant byte is always transmitted first. These values are limited to the range  $\pm 8.43 \times 10^{-37}$  to  $\pm 3.38 \times 10^{38}$  but certain parameters are limited by the meter to a narrower range (eg CT primary 1.0 to 5000.0).

## Communications

**Table 1 Instantaneous Meter Readings**

Offset	Address	Contents	Format	Bytes	Words	Access
0	256	kW 3-Ph	Float	4	2	R
1	257	kVA 3-Ph	Float	4	2	R
2	258	kvar 3-Ph	Float	4	2	R
3	259	PF 3-Ph	Float	4	2	R
4	260	Frequency	Float	4	2	R
5	261	Phase 1 Volts	Float	4	2	R
6	262	Phase 1 Current	Float	4	2	R
7	263	Phase 1 kW	Float	4	2	R
8	264	Phase 2 Volts	Float	4	2	R
9	265	Phase 2 Current	Float	4	2	R
10	266	Phase 2 kW	Float	4	2	R
11	267	Phase 3 Volts	Float	4	2	R
12	268	Phase 3 Current	Float	4	2	R
13	269	Phase 3 kW	Float	4	2	R
14	270	Phase 1 PF	Float	4	2	R
15	271	Phase 2 PF	Float	4	2	R
16	272	Phase 3 PF	Float	4	2	R
17	273	Ph1-Ph2 Volts	Float	4	2	R
18	274	Ph2-Ph3 Volts	Float	4	2	R
19	275	Ph3-Ph1 Volts	Float	4	2	R
20	276	Phase 1 kVA	Float	4	2	R
21	277	Phase 2 kVA	Float	4	2	R
22	278	Phase 3 kVA	Float	4	2	R
23	279	Phase 1 kvar	Float	4	2	R
24	280	Phase 2 kvar	Float	4	2	R
25	281	Phase 3 kvar	Float	4	2	R

All values are stored as floating point numbers in unit form (watts, volts, amps etc.).

**Table 2 Energy Registers**

Offset	Address	Contents	Format	Bytes	Words	Access
0	512	Decimal Point ❶	Long Int	4	2	R
1	513	3-Ph Wh	Long Int	4	2	R / W
2	514	3-Ph VAh	Long Int	4	2	R / W
3	515	3-Ph varh (Ind)	Long Int	4	2	R / W
4	516	3-Ph varh (Cap)	Long Int	4	2	R / W
5	517	Export Wh	Long Int	4	2	R / W
6	518	Export VAh	Long Int	4	2	R / W
7	519	Accum VA MD.	Long Int	4	2	R / W
8	520	Peak VA MD.	Long Int	4	2	R / W
9	521	Accum W MD.	Long Int	4	2	R / W
10	522	Peak W MD.	Long Int	4	2	R / W

The values in Table 2 represent the energy registers of the meter. They are stored as long integers representing the numbers displayed by the meter without a decimal point or scaling.

The Decimal Point Register ❶ defines the scaling for all registers in the table. The value is defined, automatically by the meter, dependant on the current and voltage transformer values currently set. This value is read only and may not be changed directly using serial communications.

An actual unit energy reading (eg. wh) is calculated as :

$$N \times 10^{(DP-2)}$$

**N = Register value stored in the table**  
**DP = The Decimal Point Register**

**Example :** A number displayed on the lcd as 123.45 kWh (i.e. LSB = 10 wh) would be stored in the table as 12345. The Decimal Point Register would be set to 3. The energy value would be calculated as  $12345 \times 10^{(3-2)} = 123450 \text{ wh}$ .

## Communications

### Table 3 Meter Set-up

Offset	Address	Contents	Format	Bytes	Words	Access
0	768	CT Primary	Float	4	2	R / W
1	769	PT Ratio	Float	4	2	R / W
2	770	Nominal Volts	Float	4	2	R / W
3	771	Peak Ph 1 Volts	Float	4	2	R / W
4	772	Peak Ph 2 Volts	Float	4	2	R / W
5	773	Peak Ph 3 Volts	Float	4	2	R / W
6	774	Peak Ph 1 Amps	Float	4	2	R / W
7	775	Peak Ph 2 Amps	Float	4	2	R / W
8	776	Peak Ph 3 Amps	Float	4	2	R / W
9	777	Rolling Ave kW	Float	4	2	R / W
10	778	Peak Ave kW	Float	4	2	R / W
11	779	Rolling Ave kVA	Float	4	2	R / W
12	780	Peak Ave kVA	Float	4	2	R / W

The values in Table 3 represent the basic meter set-up and are stored as floating point numbers. Peak and rolling averages are also stored here allowing them to be preset (or reset to 0) via the comms port.

**NOTE :** The value in the Nominal Volts register is factory set and does not require alteration by the user under normal circumstances.

### Table 4 Relay Set-up

Offset	Address	Contents	Format	Bytes	Words	Access
0	1024	Relay 1 Type	Integer	2	1	R / W
1	1025	Relay 1 Direction	Integer	2	1	R / W
2	1026	Relay 1 Set Point	Integer	2	1	R / W
3	1027	Relay 1 Rate	Integer	2	1	R / W
4	1028	Relay 1 Delay	Integer	2	1	R / W
5	1029	Relay 2 Type	Integer	2	1	R / W
6	1030	Relay 2 Direction	Integer	2	1	R / W
7	1031	Relay 2 Set Point	Integer	2	1	R / W
8	1032	Relay 2 Rate	Integer	2	1	R / W
9	1033	Relay 2 Delay	Integer	2	1	R / W

The values in Table 4 represent the set-up parameters of the meters internal pulsing/alarm relays and are stored as integers. The values are used to define the relay operation as shown below.

**RELAY TYPE**

Defines the function of the relay as follows :

TYPE = 0	Relay Not Fitted
TYPE = 1	kWh Pulsing
TYPE = 2	kVAh Pulsing
TYPE = 3	kvarh (Ind) Pulsing
TYPE = 4	kvarh (Cap) Pulsing
TYPE = 5	Export kWh Pulsing
TYPE = 6	Export kVAh Pulsing
TYPE = 101	kW Alarm
TYPE = 102	kVA Alarm
TYPE = 103	kvar Alarm
TYPE = 104	Average Voltage Alarm
TYPE = 105	Average Current Alarm
TYPE = 106	Power Factor Alarm (x100)
TYPE = 107	Frequency Alarm (x100)
TYPE = 108	kW Maximum Demand Alarm
TYPE = 109	kVA Maximum Demand Alarm

The most significant byte of this integer parameter should always be set to 0.

**RELAY DIRECTION**

This is used for alarm relays only (Types 101 to 109) and defines whether the alarm is activated when the measured value is under or over the preset alarm level.

DIRECTION = 0	Under Alarm
DIRECTION = 1	Over Alarm

**RELAY SET POINT**

This is used for alarm relays only (Types 101 to 109) and defines the point at which the relay is activated. The value in this register defines the set point as a percentage of full scale of the preset parameter. The range of values accepted for the majority of parameters is  $\pm 120$  corresponding to set points of  $\pm 120\%$ . If the Relay Type is set to power factor (106) the Relay Set Point table entry varies over the range 0-100 corresponding to power factors of 0.00 to 1.00. If the Relay Type is set to frequency (107) the Relay Set Point table entry varies over the range 4500-6500 corresponding to frequencies of 45.00 to 65.00 hz.

**RELAY RATE**

This is used for pulsing relays only and defines the number of counts of the associated energy register, as displayed, which will occur between each relay pulse operation. The range of values accepted by the meter are 1 to 10,000.

**RELAY DELAY**

For pulsing relays this register defines the pulse ON period, for each relay closure, in the range 100mS - 5000mS. For alarm relays this register defines the alarm delay period (ref section 6.9) in the range 0 to 10 seconds.

## Communications

---

### EXAMPLE :

A meter has a current transformer primary of 100.0A and Relay 1 programmed via the serial communication port as :

TYPE	DIRECTION	SET POINT	RATE	DELAY
105	1	60	10	5

Relay 1 will close when the average of the 3-phase currents exceeds 60% of 100.0 Amps ( 60A ) for longer than 5 seconds. The operation of pulsing/alarm outputs is covered in detail in section 6.9.

**Table 5 Analogue Output Set-up**

Offset	Address	Contents	Format	Bytes	Words	Access
0	1280	Output 1 Type	Integer	2	1	R / W
1	1281	Output 1 Range	Integer	2	1	R / W
2	1282	Output 1 % FS	Integer	2	1	R / W
3	1283	Output 2 Type	Integer	2	1	R / W
4	1284	Output 2 Range	Integer	2	1	R / W
5	1285	Output 2 % FS	Integer	2	1	R / W

The values in Table 5 represent the set-up parameters of the meters optional analogue output channels and are stored as integers. The values are used to define the outputs as shown below.

### **OUTPUT TYPE**

Defines the function of the output as follows :

TYPE = 0	Output Not Fitted
TYPE = 1	3-Phase Power Factor
TYPE = 2	Frequency (Phase 1 Volts)
TYPE = 3	3-Phase kW
TYPE = 4	3-Phase kVA
TYPE = 5	3-Phase kvar
TYPE = 6	Average 3-Phase Voltage
TYPE = 7	Average 3-Phase Current
TYPE = 8	Phase 1 Voltage
TYPE = 9	Phase 2 Voltage
TYPE = 10	Phase 3 Voltage
TYPE = 11	Phase 1 Current
TYPE = 12	Phase 2 Current
TYPE = 13	Phase 3 Current
TYPE = 14	kW Accumulating MD
TYPE = 15	kVA Accumulating MD

The most significant byte of this integer parameter should always be set to 0.

**OUTPUT RANGE**

This defines the output signal range (section 6.126.11) as :

- RANGE = 0      Unipolar Input Range
- RANGE = 1      Bipolar Input Range
- RANGE = 2      Absolute Input Range

**OUTPUT % FULL SCALE (FS)**

This defines the level of measured signal which will provide 20mA (or 16mA) at the analogue output. The value is defined as a percentage of the full scale of the parameter programmed.

The range of values accepted by the meter are 500 to 2000 corresponding to set points of 50.0% to 200.0% of the full scale<sup>1</sup>. The most significant byte is therefore always set to 0.

**EXAMPLE :**

A meter has a current transformer primary of 100.0A and an analogue output channel 1 programmed via the serial communication port as :

TYPE	RANGE	% FULL SCALE
11	0	75.0 (set point= 750)

The analogue output channel will provide 4-20mA (or 0-16mA) representing phase 1 current in the range 0-75 Amps.

The operation of analogue outputs is covered in detail in section 6.12.

**Table 6 Real Time Clock**

Offset	Address	Contents	Format	Bytes	Words	Access
0	1536	Date	Integer	2	1	R / W
1	1537	Month	Integer	2	1	R / W
2	1538	Year	Integer	2	1	R / W
3	1539	Hour	Integer	2	1	R / W
4	1540	Minute	Integer	2	1	R / W
5	1541	Second	Integer	2	1	R / W
6	1542	MD Period	Integer	2	1	R / W

The values in Table 6 represent the current Date/Time of the real time clock internal to the meter. A 24hr clock format is used.

1. When frequency is selected 50% to 200% corresponds to 50Hz to 200Hz. eg When 100% is selected 4-20mA corresponds to a frequency range 0-100Hz.

## Communications

---

### EXAMPLE :

The real time clock in a meter requires setting to 11:30 pm, the 21st of November 1995 via the communication port. The following values would be transmitted from the host :

DATE	MONTH	YEAR	HOUR	MINUTE	SECONDS
21	11	95	23	30	00

The MD Period register defines the number of minutes in each MD period. Valid values are 5, 10, 15, 20, and 30 minutes.

### Table 7 Meter Description

Offset	Address	Contents	Format	Bytes	Words	Access
0	1792	Meter Type	Integer	2	1	R
1	1793	Serial Number	Integer	2	1	R
2	1794	Software Version	Integer	2	1	R

The values in Table 7 provide details of the hardware/software configuration of the meter. These values are factory set and may not be changed via the serial communication option.

Meter Type defines the meter model. The meter types are defined as follows :

TYPE	PM390 Model
257	PM390 Basic Meter
258	PM390 Basic Meter with Pulse/Alarm Outputs
259	PM390 Basic Meter with Maximum Demand
260	PM390 Basic Meter with Maximum Demand and Pulse/Alarm Outputs

Serial numbers are integer values in the range 1 to 65000.

The software version is stored as an integer without decimal point so Version 2.10 would be stored as 210.

**Table 8 Communication Set-up**

Offset	Address	Contents	Format	Bytes	Words	Access
0	2048	Access Code	Integer	2	1	R/W
1	2049	Meter Address	Integer	2	1	R/W
2	2050	Baud Rate	Integer	2	1	R/W
3	2051	Balanced Volts	Integer	2	1	R/W
4	2052	Auto-Rotate	Integer	2	1	R/W

The values in Table 8 provide details of the software configuration of the serial communication option. Care must be taken in making changes to these values as they may affect subsequent communications.

**ACCESS CODE**

A value of 12345 must be set for the Access Code before any other byte in Table 8 may be written to. This prevents accidental access to the data in the table which may cause communications problems. This register is reset to 0 on each power up of the meter.

**METER ADDRESS**

This is the Modbus unique address for the meter and may be set in the range 0-250 using the communications port. All Modbus transactions subsequent to the one setting the address must use the new value.

**Address 0** is a special address **reserved** for factory use only and should never be set by the user.

**Address 1-247** are valid Modbus addresses but should be unique on a Modbus system.

**Address 248-250** have the effect of disabling the Programming Menu selections specific to communications (Baud Rate and Address). A value of 250 is factory set in meters with no communications hardware fitted.

**BAUD RATE**

Valid Baud Rates are 2400, 4800, 9600 and 19200. All Modbus transactions subsequent to the one setting the baud rate are carried out at the new speed.

**BALANCED VOLTS**

This defines whether balanced voltage mode (refer to section 2.10) is **OFF (0)** or **ON (1)**.

**AUTO-ROTATE**

This defines whether CT Auto Rotate mode (refer to section 2.9) is **OFF (0)** or **ON (1)**.

## Communications

**Table 21 Instantaneous Meter Readings**

Tables 21 and 22 provide read only access to the same data as Tables 1 and 2 respectively. 4-Byte variables in these tables have the upper and lower integer registers individually addressed. This feature is only available on PM390 meters with software versions of 1.10 or later.

Offset	Address	Contents	Format	Bytes	Words	Access
0	5376	kW 3-Ph	Float Hi	2	1	R
1	5377		Float Lo	2	1	R
2	5378	kVA 3-Ph	Float Hi	2	1	R
3	5379		Float Lo	2	1	R
4	5380	kvar 3-Ph	Float Hi	2	1	R
5	5381		Float Lo	2	1	R
6	5382	PF 3-Ph	Float Hi	2	1	R
7	5383		Float Lo	2	1	R
8	5384	Frequency	Float Hi	2	1	R
9	5385		Float Lo	2	1	R
10	5386	Phase 1 Volts	Float Hi	2	1	R
11	5387		Float Lo	2	1	R
12	5388	Phase 1 Amps	Float Hi	2	1	R
13	5389		Float Lo	2	1	R
14	5390	Phase 1 kW	Float Hi	2	1	R
15	5391		Float Lo	2	1	R
16	5392	Phase 2 Volts	Float Hi	2	1	R
17	5393		Float Lo	2	1	R
18	5394	Phase 2 Amps	Float Hi	2	1	R
19	5395		Float Lo	2	1	R
20	5396	Phase 2 kW	Float Hi	2	1	R
21	5397		Float Lo	2	1	R
22	5398	Phase 3 Volts	Float Hi	2	1	R
23	5399		Float Lo	2	1	R
24	5400	Phase 3 Amps	Float Hi	2	1	R
25	5401		Float Lo	2	1	R
26	5402	Phase 3 kW	Float Hi	2	1	R
27	5403		Float Lo	2	1	R

**Table 21 Continued**

Offset	Address	Contents	Format	Bytes	Words	Access
28	5404	Phase 1 PF	Float Hi	2	1	R
29	5405		Float Lo	2	1	R
30	5406	Phase 2 PF	Float Hi	2	1	R
31	5407		Float Lo	2	1	R
32	5408	Phase 3 PF	Float Hi	2	1	R
33	5409		Float Lo	2	1	R
34	5410	Ph1-Ph2 Volts	Float Hi	2	1	R
35	5411		Float Lo	2	1	R
36	5412	Ph2-Ph3 Volts	Float Hi	2	1	R
37	5413		Float Lo	2	1	R
38	5414	Ph3-Ph1 Volts	Float Hi	2	1	R
39	5415		Float Lo	2	1	R
40	5416	Phase 1 kVA	Float Hi	2	1	R
41	5417		Float Lo	2	1	R
42	5418	Phase 2 kVA	Float Hi	2	1	R
43	5419		Float Lo	2	1	R
44	5420	Phase 3 kVA	Float Hi	2	1	R
45	5421		Float Lo	2	1	R
46	5422	Phase 1 kvar	Float Hi	2	1	R
47	5423		Float Lo	2	1	R
48	5424	Phase 2 kvar	Float Hi	2	1	R
49	5425		Float Lo	2	1	R
50	5426	Phase 3 kvar	Float Hi	2	1	R
51	5427		Float Lo	2	1	R

Notes : Float Hi, Float Lo are the High and Low order integers of a floating point number

## Communications

**Table 22 Energy Registers**

Offset	Address	Contents	Format	Bytes	Words	Access
0	5632	Decimal Point	Long Hi	2	1	R
1	5633		Long Lo	2	1	R
2	5634	3-Ph Wh	Long Hi	2	1	R
3	5635		Long Lo	2	1	R
4	5636	3-Ph Vah	Long Hi	2	1	R
5	5637		Long Lo	2	1	R
6	5638	3-Ph varh (Ind)	Long Hi	2	1	R
7	5639		Long Lo	2	1	R
8	5640	3-Ph varh (Cap)	Long Hi	2	1	R
9	5641		Long Lo	2	1	R
10	5642	Export Wh	Long Hi	2	1	R
11	5643		Long Lo	2	1	R
12	5644	Export Vah	Long Hi	2	1	R
13	5645		Long Lo	2	1	R
14	5646	Accum VA MD	Long Hi	2	1	R
15	5647		Long Lo	2	1	R
16	5648	Peak VA MD	Long Hi	2	1	R
17	5649		Long Lo	2	1	R
18	5650	Accum W MD	Long Hi	2	1	R
19	5651		Long Lo	2	1	R
20	5652	Peak W MD	Long Hi	2	1	R
21	5653		Long Lo	2	1	R

Notes : Long Hi, Long Lo are the High and Low order integers of a Long Integer number

## 7.9 RTU Commands

### 7.9.1 Function 04 Read Multiple Registers

#### Description

This function allows a number of registers from a meter table to be read in a single operation. This command is commonly used to obtain instantaneous or energy reading from the meter or to upload its programmable configuration. This command is not available as a *broadcast* command as it requires a return data packet from the meter.

#### Host Request

	BYTE	EXAMPLE
METER ADDRESS	1	19 H
FUNCTION	2	04 H
TABLE NUMBER (Address High Byte)	3	01 H
TABLE OFFSET (Address Low Byte)	4	05 H
No. OF WORDS (N) (High Byte)	5	00 H
No. OF WORDS (N) (Low Byte)	6	06 H
CHECKSUM (High Byte)	7	62 H
CHECKSUM (Low Byte)	8	2D H

#### Meter Response

	BYTE	EXAMPLE
METER ADDRESS	1	19 H
FUNCTION	2	04 H
NUMBER OF BYTES (2N)	3	0C H
DATA REGISTER 1 (High Byte)	4	V1 (float) MSB
DATA REGISTER 1 (Low Byte)	5	V1 Byte 3
DATA REGISTER 2 (High Byte)	6	V1 Byte 2
DATA REGISTER 2 (Low Byte)	7	V1 LSB

DATA REGISTER N (High Byte)	2N + 2	kW1 Byte 2
DATA REGISTER N (Low Byte)	2N + 3	kW1 LSB
CHECKSUM (High Byte)	2N + 4	CRC MSB ❶
CHECKSUM (Low Byte)	2N + 5	CRC LSB ❶

The example shows a host request for data from Table 1 Instantaneous Meter Readings. The data requested starts at Phase 1 Voltage (Offset=5) and is for 6 Words (3 floats). The meter returns Phase 1 Volts, Phase 1 Current and Phase 1 kW as floating point numbers. The meter therefore returns a Byte Count of 12.

❶ The checksum received from the meter is dependant on the data transmitted.

## Communications

### 7.9.2 Function 06 Preset a Single Register

#### Description

This function allows a single integer register in a meter table to be changed by the host. This command is commonly used to program meter parameters or to reset energy registers to zero.

When broadcast (address=0) all meters on the network are addressed together but none reply.

#### Host Request

	BYTE	EXAMPLE
METER ADDRESS	1	19 H
FUNCTION	2	06 H
TABLE NUMBER (Address High Byte)	3	02 H
TABLE OFFSET (Address Low Byte)	4	01 H
DATA VALUE (High Byte)	5	C3 H
DATA VALUE (Low Byte)	6	50 H
CHECKSUM (High Byte)	7	8A H
CHECKSUM (Low Byte)	8	A6 H

#### Meter Response

	BYTE	EXAMPLE
METER ADDRESS	1	19 H
FUNCTION	2	06 H
TABLE NUMBER (Address High Byte)	3	02 H
TABLE OFFSET (Address Low Byte)	4	01 H
DATA VALUE (High Byte)	5	C3 H
DATA VALUE (Low Byte)	6	50 H
CHECKSUM (High Byte)	7	8A H
CHECKSUM (Low Byte)	8	A6 H

The example shows a host request to set the kWh energy register (Table 2, Offset 1) to 50,000 ( C3 50 Hex).

The meter responds with a repeat of the host message after the register has been successfully written.

**NOTE :** This Modbus command is limited to writing 2-byte data only. It may not be used to set floating point values (eg CT primary). Long Integer registers may be written as in the example above where the upper bytes are automatically set to zero by the meter.

### 7.9.3 Function 08 Loop Back Diagnostic

#### Description

This function provides a simple means of testing the communication network and detecting if a particular meter is present..

This command is not available as a *broadcast* command as it requires a return data packet from the meter.

#### Host Request

	BYTE	EXAMPLE
METER ADDRESS	1	19 H
FUNCTION	2	08 H
DIAGNOSTIC CODE (High Byte)	3	00 H
DIAGNOSTIC CODE (Low Byte)	4	00 H
DIAGNOSTIC DATA (High Byte)	5	03 H
DIAGNOSTIC DATA (Low Byte)	6	E8 H
CHECKSUM (High Byte)	7	E3 H
CHECKSUM (Low Byte)	8	6D H

#### Meter Response

	BYTE	EXAMPLE
METER ADDRESS	1	19 H
FUNCTION	2	08 H
DIAGNOSTIC CODE (High Byte)	3	00 H
DIAGNOSTIC CODE (Low Byte)	4	00 H
DIAGNOSTIC DATA (High Byte)	5	03 H
DIAGNOSTIC DATA (Low Byte)	6	E8 H
CHECKSUM (High Byte)	7	E3 H
CHECKSUM (Low Byte)	8	6D H

The example shows a loop back diagnostic with the test data set to 1000 (03 E8 Hex). The data byte is arbitrary.

**NOTE :** Modbus defines a number of diagnostic commands, each identified by a different code. The PM390 only supports Code=0 which returns the host command string as sent.

## 7.9.4 Function 16 Preset Multiple Registers

### Description

This function allows a number of registers in a meter table to be set, by the host, in a single operation. This command is commonly used for setting energy registers or changing the meter programmable setup parameters. When broadcast (address=0) all meters on the network are addressed together but none reply.

### Host Request

	BYTE	EXAMPLE
METER ADDRESS	1	19 H
FUNCTION	2	10 H
TABLE NUMBER (Address High Byte)	3	03 H
TABLE OFFSET (Address Low Byte)	4	00 H
NUMBER OF DATA WORDS (N) (High Byte)	5	00 H
NUMBER OF DATA WORDS (N) (Low Byte)	6	04 H
NUMBER OF DATA BYTES (2N)	7	08 H
DATA BYTE 1	8	Float 1 MSB
DATA BYTE 2	9	Float 1 [2]
DATA BYTE 3	10	Float 1 [1]
DATA BYTE 4	11	Float 1 LSB

DATA BYTE 2N-1	2N + 6	00 H
DATA BYTE 2N	2N + 7	00 H
CHECKSUM (High Byte)	2N + 8	CRC MSB
CHECKSUM (Low Byte)	2N + 9	CRC LSB

### Meter Response

	BYTE	EXAMPLE
METER ADDRESS	1	19 H
FUNCTION	2	10 H
TABLE NUMBER (Address High Byte)	3	02 H
TABLE OFFSET (Address Low Byte)	4	01 H
NUMBER OF DATA WORDS (High Byte)	5	00 H
NUMBER OF DATA WORDS (Low Byte)	6	06 H
CHECKSUM (High Byte)	7	13 H
CHECKSUM (Low Byte)	8	AB H

Command 16 may be used to preset Integers (words), Floats and Long integers equally. Floats and Long Integers are transmitted High byte first with the number of DATA WORDS (N) set to 2 x the number of registers.

The type of data sent is dependant on the Table selected. (eg Long Integer Data must be sent to preset values in Table 2).

The following example sets the CT primary current to 200.0 and the VT ratio to 1.0 in a single command using floating point data as required by Table 3.

**Example Host Request**

	BYTE	EXAMPLE
METER ADDRESS	1	19 H
FUNCTION	2	10 H
TABLE NUMBER (Address High Byte)	3	03 H
TABLE OFFSET (Address Low Byte)	4	00 H
NUMBER OF DATA WORDS (N) (High Byte)	5	00 H
NUMBER OF DATA WORDS (N) (Low Byte)	6	04 H
NUMBER OF DATA BYTES (2N)	7	08 H
CT Primary =200.0 - Byte 3 (MSB)	8	43 H
CT Primary =200.0 - Byte 2	9	48 H
CT Primary =200.0 - Byte 1	10	00 H
CT Primary =200.0 - Byte 0 (LSB)	11	00 H
VT Ratio = 1.0 - Byte 3 (MSB)	12	3F H
VT Ratio = 1.0 - Byte 2	13	80 H
VT Ratio = 1.0 - Byte 1	14	00 H
VT Ratio = 1.0 - Byte 0 (LSB)	15	00 H
CHECKSUM (High Byte)	16	2A H
CHECKSUM (Low Byte)	17	6E H

# Communications

---

## 7.10 Exception Responses

When a host sends a query to an individual meter on the network it expects a normal response. In fact one of four possible events may occur as a result of the query :

- ◇ If the meter receives the message with no communication errors, and can handle the query it will reply with a normal response.
- ◇ If the meter does not receive the message due to a communication failure, no response will be returned and the host will eventually time-out.
- ◇ If the meter receives the message but detects a communication error via its CRC, no response will be returned. and the host will eventually time-out.
- ◇ If the meter receives the query with no communication errors but cannot handle the query (out of range data or address) the response will be an **Exception Response** informing the host of the nature of the error.

An Exception Response differs from a normal response in its Function Code and Data Fields.

### Exception Response

	BYTE	EXAMPLE
METER ADDRESS	1	19 H
FUNCTION	2	84 H
EXCEPTION CODE	3	02 H
CHECKSUM (High Byte)	4	42 H
CHECKSUM (Low Byte)	5	C6H

### EXCEPTION FUNCTION CODE

All normal function types have a most significant bit of 0 (< 80 Hex). In an Exception Response the meter sets the MSB to 1 (adds 80H to the received Function Type). The Function can therefore be used by the host to detect an Exception Response.

### DATA FIELD

In an Exception Response the data field is used only to return the type of error that occurred (**Exception Code**). The PM390 Utilises the following Exception Codes :

CODE	MEANING
1	Function Code Not Supported By Meter
2	Table Number Or Offset Out Of Range Of Meter
3	Data Value Out Of Range

## Specification

### 8. Specification

INPUT VOLTAGE	
Input Type.	3-Phase, 3/4 Wire or single phase
Nominal Volts (Un).	400V Line, 230V Phase (60V Ph Optional)
Operating Range.	50% to 120% Un
Maximum Overload.	2 x Un for 2 seconds
Voltage To Ground.	300V AC r.m.s. maximum
Maximum Burden.	350uA per phase
Frequency Range.	16-550Hz fundamental
Maximum Harmonic.	Up to 20 <sup>th</sup> of 50Hz
INPUT CURRENT	
Input Type.	Current Transformers
Nominal Current (Ib).	5 Amp per phase. (1 Amp optional)
Operating Range.	0.2% to 120% Ib
Maximum Overload.	10 x Ib for 10s; 40 x Ib for 1s
Voltage To Ground.	300V AC r.m.s. maximum
Maximum Burden.	0.1 VA per phase
Frequency Range.	16-550Hz fundamental
Maximum Harmonic.	Up to 20 <sup>th</sup> of 50Hz
Isolation.	2.5kV each phase.
AUXILIARY SUPPLY	
Input Type.	Single phase + earth 45-65Hz.
Nominal Voltage.	230V ±15% as standard
Power.	Maximum 6W (9W with all options fitted)
Options.	115V ±15%
Internal Fuse.	100mA Type T (delay)
Voltage to Ground.	300V AC r.m.s maximum
Isolation.	2.5kV
OUTPUT RELAYS (OPTIONAL)	
Type.	2 x Bipolar Opto FETs
Usage.	Pulse output or alarm.
Contact Rating.	120VAC, 120mA AC/DC , 250mA DC.
Pulse Rate.	Programmable. (Maximum every 1.2 seconds)
Pulse Period.	Programmable 0.1 to 5 seconds.
Alarm Parameter.	Programmable (Displayed values only)
Alarm Set Point.	Programmable (Depends on parameter)
Isolation.	2.5kV (50V Output A to Output B)

## Specification

DISPLAY	
Type. Display Format.	Intelligent super twist custom liquid crystal (LCD) 2 rows of 4 digits (7 segment) and legends 1 row of 6 digits (7 segment)
Digit Height.	12.5mm each row
Legend Height.	4mm
Backlight.	Green/Yellow light emitting diode. (LED)
ACCURACY (45-65Hz)	
Test Conditions.	Using equipment traceable to national standards 23 °C Nominal ( $\pm 4^{\circ}\text{C}$ )
Instantaneous W.	Class 0.5 (see kWh)
Instantaneous VA.	Class 1 (see kVAh)
Instantaneous Var.	Class 1 (see kvarh)
kWh Register.	Class 0.5 (EN 61036)
kVAh Register.	Class 1
kvarh Register.	Class 1 (EN 61268)
Instantaneous Volts.	Class 0.1 EN 60688 (5% $U_n$ to 120% $U_n$ ) $\pm 1$ digit
Instantaneous Amps.	Class 0.1 EN 60688 (5% $I_b$ to 120% $I_b$ ) $\pm 1$ digit $\pm 0.2$ degrees
Instantaneous PF. Frequency.	0.002Hz, $\pm 1$ digit
GENERAL	
Temperature.	Operating $-10^{\circ}\text{C}$ to $+55^{\circ}\text{C}$ , storage $-25^{\circ}\text{C}$ to $+70^{\circ}\text{C}$
Humidity.	Operating <75% Non Condensing
Memory.	25 years in event of power failure 15 Years for MD versions
Environment.	IP55 When mounted in a panel
Safety.	IEC 1010 (Installation category 3)
EMC	89/336/EMC EN 50081 : 1992 Part 1 EN 50082 : 1995 Part 2
MECHANICAL	
Dimensions.	96 x 96 x 139mm
Material.	Noryl GFN 2 SE
Weight.	800g maximum

COMMUNICATIONS	(OPTIONAL)
Type.	RS422 or RS485 multidrop (RS232 alternative)
Data Format.	1 Start bit , 8 data bits, 1 Stop Bit.
Protocol.	Modbus. RTU framing, binary data with CRC
Baud Rate.	2400 to 19200 programmable.
Address Range.	1-247 programmable. (must be unique)
Number of Meters.	Up to 32 on standard RS422/RS485 Up to 247 with external line repeaters.
Isolation	2.5kV

DUAL ANALOGUE	(OPTIONAL)
Type.	Isolated d.c. loop/internal powered current.
Output Current.	4-20mA or 0-16mA selectable
Input Range.	Programmed proportional to measured value..
Scaling.	Programmable 50-200% of input.
External Supply.	18V(min), 24V(nom), 30V(max) d.c. @ 30mA d.c. per meter.
Internal Supply	18V Nominal @ 60mA
Accuracy	Measured Parameter $\pm 0.5\%$ fs
Isolation	2.5kV
Isolation Output A-B	50V

**Nominal Values And Measurement Ranges**

<b>PARAMETER</b>	<b>FULL SCALE</b>	<b>RANGE % F.S.</b>
<b>3-Ph kW</b>	3 x Vnom x CT Prim x PT Ratio	-144% to +144%
<b>Phase kW</b>	Vnom x CT Prim x PT Ratio	-144% to +144%
<b>3-Ph kVA</b>	3 x Vnom x CT Prim x PT Ratio	-144% to +144%
<b>Phase kVA</b>	Vnom x CT Prim x PT Ratio	-144% to +144%
<b>3-Phase kvar</b>	3 x Vnom x CT Prim x PT Ratio	-144% to +144%
<b>Phase kvar</b>	Vnom x CT Prim x PT Ratio	-144% to +144%
<b>Phase V</b>	Vnom x PT Ratio	0% to +120%
<b>Phase I</b>	CT Primary	0% to +120%
<b>Power Factor</b>	1.00	-0.0 to 1.00 to +0.0
<b>kWh</b>	9 9 9 9 9 9	0 to 999999
<b>kVAh</b>	9 9 9 9 9 9	0 to 999999
<b>kvarh (Ind)</b>	9 9 9 9 9 9	0 to 999999
<b>kvarh (Cap)</b>	9 9 9 9 9 9	0 to 999999
<b>Export kWh</b>	- 9 9 9 9 9 9	-999999 to 0
<b>Export kVAh</b>	- 9 9 9 9 9 9	-999999 to 0
<b>3-Ph kW MD</b>	3 x Vnom x CT Prim x PT Ratio	-144% to +144%
<b>3-Ph kVA MD</b>	3 x Vnom x CT Prim x PT Ratio	-144% to +144%

**Table 8-1 Full Scale Values**